

# CRAFT CONTACTS

December, 1995; ISSN 0319-8873

Craft Contacts is published six times annually by

**cabc**

Crafts Association of British Columbia  
1386 Cartwright Street, Granville Island  
Vancouver, British Columbia V6H 3R8  
TEL: 687-6511 FAX: 687-6711

*The Crafts Association of British Columbia promotes the development and appreciation of British Columbia artisans and their crafts.*

## THANK YOU!

A special thank you to the craft artists who participated in the guided studio tours as part of the Enriching Our Environment Symposium.

<b>Granville Island</b>	<b>1000 Parker Street</b>
Pat Cairns	Wayne Arsenault
Nancy Davidson	Judson Beaumont
Barbara Heller	Gwen Boyle
Ruth Jones	Ian Cummings
Jean Kares	Veronica Foster
Iiona Barakso Lindsey	Rick Foubert
Lisa Samphire	Frederika Rahn
Kajja Tyni-Rautainen	Ruth Scheuing

## INSIDE...

"Enriching Our Environment" ..... 2  
Symposium Review ..... 3  
Creative Arts Show ..... 4  
Candlesticks Held Over ..... 9  
Craft Calendar ..... 10  
Plus more of our regular features!



Craft artist Barbara Heller at work in her Granville Island Studio. Photo by Melanie Boyle.

## cabc

Crafts Association of British Columbia  
1386 Cartwright Street, Granville Island  
Vancouver, British Columbia V6H 3R8  
TEL: 687-6511 FAX: 687-6711

### BOARD OF TRUSTEES

Ilena Barakso Lindsay Patti Koenig  
Alik Gladwin Jennifer MacMillan  
Erika Justman Rowell-VP Eric Allen Montgomery  
Shiryn Karmali Ruth Scheuring  
Margaret Klajnert Trudy Van Dop-Pres.

### STAFF

**Executive Director:** Valerie Jones  
**Carthouse Manager:** Jo Darts  
**Editing and Production:** Peter Ross,  
**Bookkeeper:** Ann Wray  
**Office Administrator:** Patricia Hansen

### REGIONAL REPS

**Victoria** Okanagan-Boundary  
Meira Mathison Peter Flanagan  
R.R.1, Pearson College R.R.1, Site 5, C-22  
Victoria, B.C. Peachland, B.C.  
V9B 5T7 V0H 1X0  
391-2411 Home - 767-2540  
Work - 767-2010

**East Kootenay** Lillooet-Thompson  
Suzanne Ashmore Chuck St. John  
P.O. Box 91 General Delivery  
Wasa, B.C. Pnanan Lake, B.C.  
V0B 2K0 V0E 3E0  
422-3547 573-3392

**Central Kootenay** Mid-Vancouver Island  
Angelika Weith Allan Burgess  
801 Park Street R.R.1, Site 38, Comp. 12  
Nelson, B.C. Comox, B.C.  
V1L 1H2 V9N 5N1  
352-2752 339-6776

**Mid-Vancouver Island**  
Ted Jolda  
122 West Fern Road  
Qualicum Beach, B.C.  
V9K 1T5  
752-1112

### VOLUNTEERS

Julie Armstrong Tony Darts  
Eleanor Blackwood Peter Desmet  
Melanie Boyle Magdalena Dudzic  
Susannah Carnie Hollie Facey  
Marth Casey-Knight Richard Finch  
Eddie-Cruz Walter Gibson  
Clare Cullen Shirley Gunawan

### SPONSORS' HONOUR ROLL

Without the dedication and support of our sponsors, the Crafts Association of British Columbia would have to expend valuable resources on many non-crafts related activities. We really appreciate the commitment these donors make to the CABC.

**THE PRINTING HOUSE LTD**



**BEAUTIFUL BRITISH COLUMBIA Gift Shops**



ARCA BELLA

FINE CRAFTS AND COLLECTIBLES



Granville Island



WANING DESIGN

**Canadian**  
Canadian Airlines International



City of Vancouver



Province of British Columbia  
Ministry of Small Business,  
Tourism and Culture

**WESTERN LIVING**

*Defy 94 Challenge 94*

**OCEAN**

**CMHC SCHIL**

Mackenzie Flusawa, Brewster  
STREVENSON KOENIG  
BARRISTERS AND SOLICITORS



Green College  
University Of British Columbia

Margaret Klajnert  
Textile Studio

Alcan Lectures On Architecture

Architectural Institute  
Of British Columbia

Award Magazine

Design BC

Emily Carr College Of  
Art And Design

Interior Designers' Institute  
Of British Columbia

Terra Breada

Linda Hale	Joy Jubenville	Charlotte Lightburn	David Sproule
Amy Hinrichs	Rosemary Kaijoka	Nadine McConnan	Ingrid Su
Robert Hornal	Kandice Kwok	Carlos Mendes	Rosanna Tsao
Shelia Hynka	Denise Lai	Eric Montgomery	Jan Tollefson
Margaret Hyslop	Christine Lawrence	Cynthia Nugent	Masumi Wada
Nancy Huggins	Michael Lawlor	Elizabeth Owre	Moyra White
Shelley Ikegami	Patrick Lavouezo	Lori Prest	Camille Winchester
Jane Irwin	Lisa Light	Maria Roth	Betty Wray

# THE PRESIDENT'S MESSAGE



**BY TRUDY VAN DORP**—Holiday Wishes.

The past few months have been busy for our staff and for our board. Our Craft and Architecture Symposium was a great success and we have included details for you in this newsletter.

The board is happy to announce that we have a new Executive Director. Valerie Jones resigned from the Board on Oct. 24, and on Nov. 1 brought her familiarity with CABBC's outstanding aims and concerns to her new role of Executive Director. Valerie has been a long serving member of the Craft & Architecture committee, has a strong belief in the power of the created object to connect people, and as Head of

Docent Programs at the Canadian Craft Museum in 1993 saw the first appearance of "Made by Hand: The Pleasures Of Making." One of CABBC's major challenges in the next year will be to produce a body of work to follow this exhibit, with its inspiring use of subsidiary materials validating the creative process.

Patricia Hansen joined us for fifteen weeks on Nov. 7, and will work with us on volunteer, membership, gallery, retail, resource, and management programs. The board would like to thank Fiona for her contribution and wishes her all the very best in her new endeavours.

Craithouse is decked out for the holiday season and looks wonderful - we encourage you to do your Christmas shopping with us - Jo has a wonderful selection of beautiful hand crafted gifts perfect for you and your loved ones.

I would like to take this opportunity on behalf of the board to extend our warmest wishes to you and your families for this special season and a very happy and prosperous new year!!

## HAPPY HOLIDAYS

CABBC wishes you all Happy Holidays, however and whenever you celebrate them, and the best of all beginnings for 1996.

## VOLUNTEERS

Volunteer Appreciation night is planned for Wednesday, January 24. Please mark your calendars for an early evening reception at Craithouse. ~

# Join The Crafts Association Of British Columbia

General \$47     Student/Senior \$30     Family \$62  
 Affiliate \$65     CABBC Patron \$150

### Benefits Of Membership:

- ☆ Craft Contacts Monthly Newsletter
- ☆ Resource Centre
- ☆ Portfolio Registry
- ☆ Video Lending Library
- ☆ Yearly Scholarship Awarded
- ☆ 10% Discount In Craithouse Gallery/Shop

My donation of \$ \_\_\_\_\_ is enclosed

NAME \_\_\_\_\_

ADDRESS \_\_\_\_\_

CITY \_\_\_\_\_ PROVINCE \_\_\_\_\_

POSTALCODE \_\_\_\_\_ PHONE \_\_\_\_\_

Yes, I would like to volunteer!

Send cheque to: CABBC,  
1386 Cartwright St., Vancouver, BC  
V6H 3R8

*Opinions expressed in Craft Contacts are those of the authors, and do not necessarily represent that of the Crafts Association Of British Columbia.*

*We gratefully acknowledge the financial support of the Government of British Columbia through the Ministry of Small Business, Tourism and Culture.*

# ENRICHING OUR ENVIRONMENT CRAFT & ARCHITECTURE

# W

hen I joined CABC's Board just over two years ago, the craft and architecture symposium as we referred to it then was little more than an idea. It is hard to believe, given board and staff fluctuation, that "Enriching Our Environment: Craft & Architecture" actually took place. It did, and with success!

Our objective was to promote a greater understanding between the communities of craft, design, and architecture. An indication of that success was evident in CABC's collaborating and co-sponsoring of Michael Ferrune, master furniture designer/craftsperson as featured speaker for the Alcan Lecture Series On Architecture, and as visiting speaker on international issues at UBC.

Originally, Michael Fortune was to have opened our symposium at Emily Carr but a conflict of schedules dictated that his talks occur in

later September. They were enormously successful with a mainly student audience at UBC and close to two hundred individuals attending the Alcan evening.

Scheduling his visit in September actually worked to our advantage because it allowed us to extend the discourse on integrating and promoting craft within the building communities. Bo Helliwell and Kim Smith of Blue Sky Architecture appropriately established that link with the Alcan Lecture through their opening remarks in which they talked of their recent visit

with Michael Fortune in his Ontario studio and presented slides of his studio and works.

The panel discussions of Saturday, Oct. 28 were both different in style and content. All the participants freely took time from their professional careers to share their perspectives. As with all events, you have some moments that shine brighter than others. Regardless, the combined energies created a forum for discussion and dialogue that wound up the afternoon's panel discussion and spilled over into the reception that followed. Sunday's

studio tours were well attended and provided a more intimate setting for understanding craft, the craft artist, and his/her working environment.

This symposium was conceived as a catalyst to develop linkages with the architecture and design communities. The dialogue has only begun, with further collaborative projects envisioned. As chair of the symposium committee, I would like to thank everyone who was involved with the project. A very special thanks go to those who were there to bring it to fruition.

—Erika Justmann Rowell

# THE ENRICHING OUR ENVIRONMENT REVIEW

**BY ANN ROSENBERG**—At symposiums, the effectiveness of the presenters' messages depends on their ability to speak to the occasion by being on topic, by having a sense of the attendees' expectations and by demonstrating respect for the audience's level of sophistication. In relative terms, "Working Together" was worthwhile because four panelists could verbally articulate and visually demonstrate how deliberating with clients and/or collaborating with artists could create challenges that led to experimentation and striking results.

Bo Hellwell and Kim Smith, the first speakers, are the founders of Blue Sky - an architectural firm based on Hornby Island that specializes in houses that resemble sculptures. These residences feature a variety of wood constructions, including some which could only be executed by an expert art/craftsperson. It was appropriate that John Grunewald spoke next, for he could explain the techniques used in the building of two circular staircases installed in Blue Sky homes. As further proof of his range of wood wizardry, Grunewald produced images of a huge Modernist boardroom table fabricated from wood-veneerred Styrofoam that could be put up in a flash for a meeting, then later vanished into a cupboard. This lightweight piece contrasted sharply with a dolmen-like table constructed of cedar slabs that would give a man as pumped up as Arnold Schwarzenegger a hernia to lift. The clients who commissioned this table had to wait three years while the artists located the necessary logs and allowed the wood time to cure before transforming the table of their dreams into reality. Joel Berman was also pretty lucid about the ways he collaborated with clients, other designers in his firm, and the manufacturers of the glass for the dividers, walls, and walkways he

produces for commercial and domestic spaces. Like the Blue Sky partners and Grunewald, Berman became most animated when he described projects where unique solutions were reached because of unusual client requests or grew from the resolution of a technical problem. But whereas the other three presenters were willing to put in extra work for free if circumstances warranted it, Berman came across as a time-is-money kind of guy. Because pertinent slides illustrated the attitudes of the "Working Together" panelists and because they all spoke about matters and processes that could apply, at least tangentially, to most art/craft practitioners situations, this part of the symposium offered something to the majority of participants. In contrast, the more abstract theme of "Public Access" was less well-addressed in the afternoon.

Moderator Isabel Corral began by posing some essential questions, for example, "What is Public Space, and who is served by art in public spaces?" While her slides attested to a fascination with streets enriched by crafted elements like the wrought-iron verandas encountered in New Orleans, there was no opportunity to discuss the issues raised and Corral didn't have the time to elucidate her stance on the role of art/craft in the city environment. It was obvious that Peter Cardew, architect of the wonderful new Morris and Helen Belkin Art Gallery at the University of British Columbia built excellent public edifices himself, but artisans were only of interest to him as resolvers and executors of elements essential to his design aesthetic. Landscape architect Don Vaughan spent most of his allotted time venting frustrations over artists who failed to meet deadlines. He showed no example (good or bad) to support the credibility of his take on the

public art scene and only when questioned did he offer guidance to the symposium attendees who wished to place their works in the public realm. Interior designer Alda Pereira chose to single out Gaudi, whom we all know, as the principle exemplar of her criteria for



**Ann Rosenberg and Erika Justmann Rowell chat with delegates at the symposium. Photo by Melanie Boyle.**

success in design, instead of showing her own Vancouver work which certainly most people in the audience had never seen, as proof of her ability to outfit private or corporate environments.

If I had been a paying customer, not a reviewer, I'd likely have gone off into the afternoon long before Lynn Bassa (Director/curator of the public art program of the University of Washington Medical Centre) and that would have been a pity, because I would have missed a most stimulating description of a public art program and the process by which it is selected that, in my view, was the highlight of the day. However, when the second question period began, there was a flurry of queries that the panelists responded to with energy and clarity, so "Public Access" was more worthwhile in the end, than it seemed at the beginning or in the middle. ☺

# CREATIVE ARTS SHOW HIGHLIGHTS HUGE

## TALENT

BY DIANNE MACDOUGALL

The talent and entrepreneurial skills displayed at the fall B.C. Creative Arts Show in Vancouver beat all records for innovation and inspiration. Now's the time to consider applying for the spring show, taking place March 10-12.

In September, 123 artists, manufacturers, and entrepreneurs exhibited their products as part of the Southern Vancouver Gift Show at Vancouver's BC Place Stadium.

The Ministry of Small Business, Tourism and Culture sponsors the bi-annual B.C. Creative Art Show to introduce home-based businesses in the arts, crafts and gift-producing industry to the wholesale market.

The contacts and exposure gained through the show launches many participants into full-time production to meet an expanded demand. All participants are home-based businesses. Many are making the leap from selling products directly to the end-user to selling to retail outlets.

Ministry of Small Business coordinator Lois Looman explains that the show enables participants to *really* focus on their image, their product, their market niche, and most importantly - on developing their entrepreneurial skills. "This show has increased the whole standard of professionalism for the home-based gift industry," Looman says.

The show focuses on business education. Exhibitors are taught how to prepare for the show - everything from booth design to preparing order forms, price lists, hang tags, packaging, label-

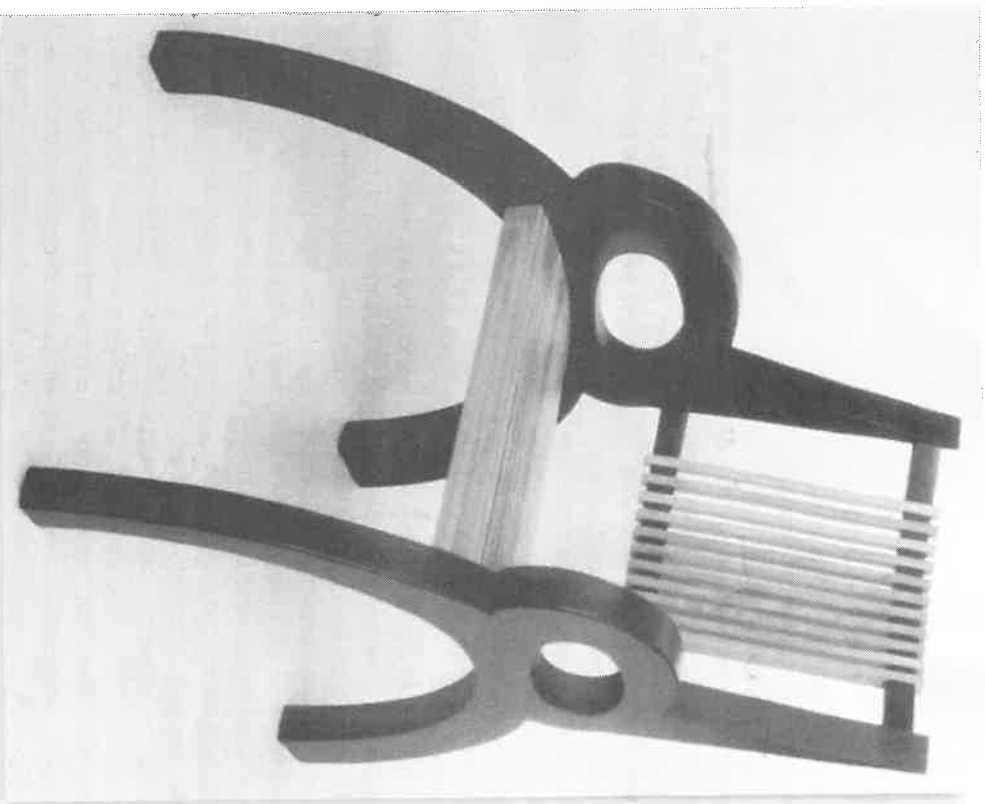

**Chair by Vincent Dedame, Vision Design Furniture**

ling, and promotional literature. There's also a fair bit of motivational training.

To exhibit at the B.C. Creative Arts show, manufacturers must submit a Call for Entry Form (available now at Chambers of Commerce and Government Agents offices). An important step for this application process is the adjudication of products by merchandise and marketing professionals.

Each product submitted for adjudication receives a written summary of judges' comments. Feedback focuses on what's needed for products to be successful in the retail gift market. Products that need additional work to meet the program's standards may be re-submitted again for no additional cost.

Four Awards Categories were featured in the fall show, with the following exhibitors receiving special plaques from the Ministry of Small Business:

- 🌟 *Vincent Dedame of Vision Design* for Most Innovative Gallery.
- 🌟 *Peter and Sharman Wieser of Unlimited Gourmet Foods* for Best Specialty Food Booth.
- 🌟 *Nick Craddock-Heny and Niccole Delvies of Nic(K)Snacks* for Best Booth Design; and
- 🌟 *Denise DeBeeld of Fishbone Etcetera Design* and *Mike Harvey and Richard Mackenzie of Mako and Mackenzie* (dual recipients) for Best Returnees. 🍷

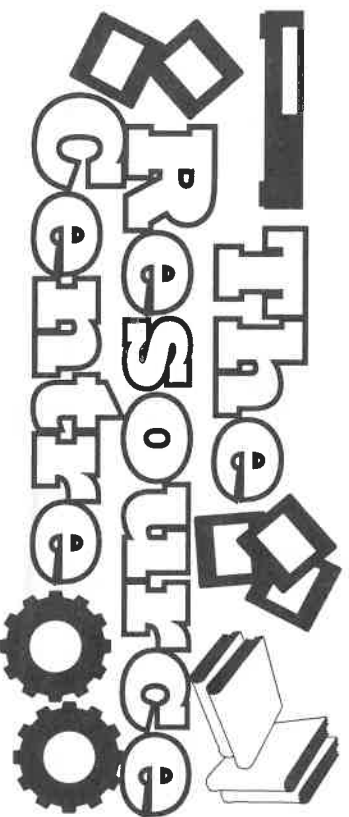

**T**he CABRC Resource Centre provides a wealth of information for craftspeople and the general public. Located in the CABRC offices and open by appointment on Friday afternoons, the Resource Centre includes the Video Lending Library, the Portfolio Registry, and the Resource Library. For more information or to make an appointment, contact Patricia Hansen at 687-6511 or FAX 687-6711.

### **Video Lending Library**

A resource of 48 titles available for loan to artists/craftspeople, educators, curators, architects/designers, collectors, and others interested in crafts. Videos feature profiles of artists and their work in clay, fibre, glass, metal, and mixed media. For a complete list or to borrow any of these videos, contact the CABRC office at 604-687-6511, or fax 604-687-6711.

### **The Portfolio Registry**

The Registry contains portfolios of CABRC members displayed in a format that provides easy access to other professionals. To join the Registry, send us:

- ★ 6-8, 35 mm slides of your work.
- ★ A typed resume or CV.
- ★ Published material about you or your crafts.

The Registry is updated periodically and submissions may be made at any time. If you already belong to the Registry, you should update your portfolio periodically to make sure your submission contains current material and is in the appropriate format.

### **The Resource Library**

#### *Publications*

- ★ *Start And Run A Profitable Gift Basket Business*. Self Counsel Press, 1995.
- ★ *Crafts In Ontario: Shop And Galleries*. Ontario Crafts Council, 1994.
- ★ *Suppliers Of Craft Materials In Ontario*. Ontario Crafts Council, 1994.
- ★ *Photographing Your Craftwork*. Steve Melzer, 1986.
- ★ *Annual Craft Shows In Ontario*. Ontario Crafts Council, 1995.

#### *Periodicals/Newsletters*

- ★ *Canadian Workshop - The Do-It-Yourself Magazine*.
- ★ *Needle Yarns*. Newsletter from the North Shore Needle Arts Chapter.

#### *Bulletin Boards*

Located at the back of Crafthouse, just before you go up the stairs to the Resource Centre, you'll find bulletin boards. They hold lots of information about current exhibitions, seminars, studio space, calls for entry, and job opportunities that are available in the arts.

### **Resource Guide 1996/97**

#### *Attention Members!!*

We are currently compiling information for our next Craftsper-son's Resource Guide to B.C. If you have any updates for the following sections, please fax Patricia Hansen the information at (604)687-6711, or phone (604)687-6511 on Tues. - Fri.

1. Retail Outlets
2. Native Art & Retail Outlets
3. Craft Fairs
4. Suppliers - this is a big area that needs work. If crafts-people know of suppliers that would like to be listed, please make sure they give me a call.

*CraftHouse*

CRAFTS ASSOCIATION OF BRITISH COLUMBIA  
1386 CARTWRIGHT STREET, GRANVILLE ISLAND  
VANCOUVER, BRITISH COLUMBIA V6H 3R8  
TELEPHONE: 687-7270 FACSIMILE: 687-6711  
CRAFTHOUSE MANAGER: JO DARTS

# High Tea

Various Artists - December 7 - 31 In The Alcove Gallery



"Canada Goose Teapot," by Mariko Paterson, 1995

Featuring Suzy Birstein, Georgina Brandon, Linda Chelak, Peter Flanagan, Jay MacLennan, Mariko Paterson, Pamela Nagley-Stevenson, Fredi Rahn, Terry Ryals, Kinichi Shigeno, Pat Taddy, and Judy Weeden. Both functional and non-functional teapots will be included, made from porcelain, terra cotta, and stoneware, as well as some teapot jewellery. As an adjunct to the show, the shop will feature teacosies, mugs, and creamers with sugar bowls. Purchases can be removed before the show ends. ☺

# REGIONAL TEXTILES

Various Artists - Jan. 4-30

This show will feature textiles from CABC members from outside the Lower Mainland, and blown glass from Ted



"Circles - Middle," detail, by Angelika Werth

Craft  
house pro-

vides an outlet for  
the display and sale of  
fine traditional, contemporary,  
and leading edge crafts; and provides  
information and education to the CABC  
membership, general public, professionals  
in the visual arts community, and  
craftspeople. CraftHouse aims to be self-  
supporting in its promotion of craft.

## NUMBERING SYSTEM

The inventory sheet mailed to CraftHouse artists (together with a letter of instructions for coding work) is your copy and is only brought to Crafthouse so you can transfer the items to our sheet. Crafthouse staff will then sign your sheet, return it, and then you take it home and maintain for your records. Bring the same sheet with you each time you bring new work to Crafthouse. I hope this clarifies any confusion.

## DECEMBER HOURS

Dec. 1-15 ..... 10 am - 6 pm  
16-23 ..... 9 am - 7 pm  
24 ..... 9 am - 3 pm  
Closed  
Christmas Day  
Boxing Day  
New Year's Day

## SALE

Presenting the First Ever Crafthouse Sale, Jan. 2-14, 1996.  
Customers Members: ..... 15%  
Customers Non-Members ..... 10%  
Crafthouse artists only absorb 5% of the members discount. Crafthouse artists who do not want to participate in the sale should immediately contact Jo Darts, Crafthouse Manager.

## 6 CRAFT CONTACTS

**LOST JEWELLER**  
Does anyone know how we could locate jeweller Kenneth Sherman? Crafthouse would like to forward an outstanding cheque to him.

## THANKS

Appreciation to Doug Graf of the Coffee Roaster, Granville Island Market for the loan of coffee equipment for the Nov. early opening for the holiday season.

The following craftspeople have generously donated pieces to Crafthouse that will help address the aim of being self-supporting in promotion of craft. We are happy to provide complimentary gift wrapping with these purchases.

Anderson Originals	Charmian Nimmo
Andrighetti Glassworks	Betty Pehme
Suzy Birstein	Margery Powell
Peter Dean	Fredi Rahn
Patricia Fortin	Adele Samphire
Marta Hylkova	Phillip Smith
Ted Jolda	Suzanne Summersgill
Malcolm MacFadyen	Mona Tudor
Jeanne Mah	Brian Tyson
Eric Montgomery	Mary Ursulak
Jeanne Morrow	

And thanks to those artists who have brought in work since this newsletter was published.

Jolda, Regional Representative for Mid-Vancouver Island. Ted has been blowing glass since 1985. His works have graced the tables of royalty, heads of state, and other fine homes. His pieces have gained him many awards from competitions in Canada and around the world. He has taught extensively in both Canada and Australia. ☺

## VOLUNTEERS

A big welcome to the following new volunteers: Rosemary Kaijoka, Magda Dndzic, Clare Cullen, and Sheila Hynka. Our volunteers Jane Irwin and Holli Facey will be moving onto greener pastures. A big thank you for your involvement in the past.

## SHOP TALK

The Crafthouse Shop Committee extends best wishes and every success to Jane Irwin for her contribution to the Crafthouse Committee as she moves on to other projects. We look forward to working with and welcoming Richard Finch and Walter Gibson to the committee.



# THE 1996 ALCOVE GALLERY CALENDAR

<p><b>JANUARY</b></p> <p><b>Jan. 4 – Jan. 30</b></p> <p><i>Regional Textiles:</i> Various artists. Textiles from CABG members from outside the Lower Mainland.</p>	<p><b>FEBRUARY</b></p> <p><b>Feb. 1 – Mar. 5</b></p> <p><i>Metal Minded: A discovery of art jewellery and ornament.</i> Curators Rachelle Geneau and Hollie Facey feature the works of various artists who have created one-of-a-kind works focusing on personal symbolism.</p>	<p><b>MARCH</b></p> <p><b>Mar. 7 – Apr. 2</b></p> <p><i>Easter – Past Lives:</i> David Zawaduk. Bold and colourful ceramic plates, bowls, vases, and wall pieces reflecting Ukrainian origins and style.</p>	<p><b>APRIL</b></p> <p><b>Apr. 4 – Apr. 30</b></p> <p><i>Willow Baskets And Beyond:</i> Alastair Heseltine. Contemporary baskets and structures based on classical European willow work.</p>
<p><b>MAY</b></p> <p><b>May 2 – June 4</b></p> <p><i>Miniature Fiber Exhibition.</i> Group show curated by Margaret Klajnert.</p>	<p><b>JUNE</b></p> <p><b>June 6 – July 2</b></p> <p><i>Lattework – Craft Turns To Art For Our Time:</i> Mark Salusbury. The great renaissance of the ancient craft of woodturning is here...for the 90s and beyond.</p>	<p><b>JULY</b></p> <p><b>July 4 – July 30</b></p> <p><i>Conjunction.</i> Debbie Andrews. Papier mache bowls that represent the flow of creative energy and the infusion of reverence that is felt for the spirit of nature surrounding the artist in the Rocky Mountains.</p>	<p><b>AUGUST</b></p> <p><b>Aug. 1 – Sept. 3</b></p> <p><i>Where Dragonflies Live.</i> Nancy Walker. Handbuilt clay bowl sculptures journey along vertical layers of landscapes, cityscapes, and dreamscapes. Whimsy and time meet.</p>
<p><b>SEPTEMBER</b></p> <p><b>Sept. 5 – Oct. 1</b></p> <p><i>...In Celebration Of Kakai:</i> Alumni of Kakai Papers. Handmade paper and book arts in Vancouver, curated by Ann R. Vicente.</p>	<p><b>OCTOBER</b></p> <p><b>Oct. 3 – Nov. 5</b></p> <p><i>Visual Cantos:</i> Vivienne Pearson. Felted works by the 1995 Grace Cameron Rogers Scholarship winner.</p>	<p><b>NOVEMBER</b></p> <p><b>Nov. 7 – Dec. 3</b></p> <p><i>Artesserapture:</i> Nina Digiovanni, Richard Finch, Walter Gibson. Functional art for the home incorporating glass, stone, ceramic, marble, wood, and cement.</p>	<p><b>DECEMBER</b></p> <p><b>Dec. 5 – Dec. 31</b></p> <p><i>Holiday Group Show</i> Various artists.</p>

## SHOP COMMITTEE

The Crafthouse Shop Committee consists of:  
 Jo Darts – Crafthouse Manager  
 Richard Finch

Walter Gibson  
 Aiki Gladwin – Co-Chair  
 Valerie Jones  
 Margaret Klajnert

Patti Koenig  
 Jennifer MacMillan – Co-Chair  
 Eric Montgomery

# THE NEWS

## GOVERNMENT

The Canada/BC Business Service Centre has joined the information super-high-way and is the first federal-provincial business service centre in Canada to go on-line on the Internet. The joint federal and provincial "one-stop shop" is on-line on the World Wide Web providing business information on a wide range of government programs and services at <http://www.sb.gov.bc.ca/>.

## STATS

According to Statistics Canada, attendance at theatres, music, dance, opera and other performing arts venues declined 2.5% between 1992/93 and 1993/94. On the other hand, after declining 0.5% in 1992/93, attendance at BC museums, art galleries, and other heritage institutions increased 3.8% in the 1993/94 fiscal year.

## TORONTO LECTURES

The Craft Studio is offering a series of lectures to be given by art historians from the Victoria and Albert Museum. The lectures will be given at the York Quay Centre in Toronto. Topics include: *British Design, 1851-57*, Jan. 25, *Studio Pottery And The New Glass Gallery*, Feb. 15, and *Japanese Clothing Culture*, Mar. 14. All lectures take place at 8 pm. Tickets available at the Harbourfront Centre Box Office 416-973-4000.

## CONGRATULATIONS

Nicole Dextras and Helen Piddington are the BC recipients of the Sheila Hugh Mackay Foundation's second bi-annual grants for 1995. The Foundation was established to promote public knowledge, participation in, and appreciation of Canadian arts and crafts, and their importance in the cultural heritage of Canada.

## FORTUNE HEADS CENTRE

Canada's pre-eminent furniture designer Michael Fortune has been hired to head up the Kootenay School Of The Arts, Centre Of Craft And Design. Fortune has more than twenty years experience as a designer/woodworker and was the 1993 recipient of the country's most prestigious crafts award, the Saideye Bronfman Award for Excellence. He has exhibited and sold his work nationally and internationally and has had it featured on CBC TV as well as in *Fine Woodworking* magazine.

Fortune has worked on value-added projects in developing countries including Trinidad, Mexico, and Belize to help design furniture and train local workers in manufacturing methods. He was also the keynote speaker at last Fall's Kootenay Value-Added Wood Forum in Creston. Currently, Fortune runs the Michael C. Fortune Studio in Toronto where with a staff of three he designs and produces one-of-a-kind commissioned pieces.

## CAR JACK EMBOSSING

*E. Bud Wertheim came up with this innovative use for his car jack. You can contact E. Bud at 72603.734@CompuServe.ca*

No no no!!! Not OUTSIDE!... you use a car scissor jack or hydraulic jack INSIDE!!! <999> You take two hunks of wood or metal plate and put threaded rods in each corner and then put the jack on the lower plate. Then you put a hunk of wood on top of the jack (or under the jack) and the embossing plate and paper inbetween. THENNNNN you crank it up and it presses the two together and PRESTO!! an embossing.... You gotta wet the paper first but not soak it. Just sorta dampish. Let the paper stay damp long enough to soften the fibers, a bit (about 20 minutes between blotters)..... I made up a press like that and used it for 20 years... Not fast but very, very effective.

## BRONFMAN WINNER

Louise Genest, world renowned Master Bookbinder and a leader among Canadian Bookbinders, has been named recipient of the 1995 Saideye Bronfman Award, Canada's preeminent distinction for excellence in the crafts.

Chosen from a diverse group of seventeen nominees celebrated for their creative contribution to Canadian crafts, Louise Genest was honoured for her inspiring, intuitive and passionate contribution to the bookbinding craft. The Award was presented on Nov. 14 in Montreal at the Canadian Centre for Architecture.

- Includes:**
- Retail Outlets
  - Galleries
  - Craft Fairs
  - Suppliers
  - Education
  - Craft Guilds
  - Organizations

### Return to:

Crafts Association of B.C.  
1386 Cartwright St., Granville Is.  
Vancouver, British Columbia  
V6H 3R6

## THE CRAFTSPERSON'S RESOURCE GUIDE TO BRITISH COLUMBIA 1994/95

Yes, I am a CABC Member!  
Send me one Resource Guide for \$8.56 (plus \$2.00 p&h).

No, I am not a CABC Member yet.  
Send me one Resource Guide for \$9.63 (plus \$2.00 p&h).

Payment Enclosed  Visa/Mastercard

NAME \_\_\_\_\_

STREET \_\_\_\_\_

CITY \_\_\_\_\_ PROV. \_\_\_\_\_ CODE \_\_\_\_\_

PHONE \_\_\_\_\_ FAX \_\_\_\_\_

VISA/MASTERCARD NUMBER \_\_\_\_\_ EXPIRY DATE \_\_\_\_\_

SIGNATURE \_\_\_\_\_

# Candlesticks

October 1 To Mid-January, 1996  
Terminal 3  
Pearson International Airport  
Mississauga, Ontario

The Crafts Association Of British Columbia takes flight with the wit and whimsy of candlesticks. Artists include Jeff Burnette and Lisa Samphire, Nina Digiovanni and Marcus Sabathil, James Koester, Brooke Hannah, Eva Mansson, David Milligan, Chuck St. John, Nancy Walker, and Mark Was.

Sponsored by Canadian Airlines, Terminal Three Limited Partnership, the Claridge Collection, and the financial support of the Government Of British Columbia through the Ministry Of Small Business, Tourism And Culture.

# Helpful Over!

## ALCAN ARCHITECTURE SERIES

Alcan presents a series of lectures at the Robson Square Conference Centre, Vancouver, BC. Free admission. Lectures begin at 6:00 pm.

January 17

"A New Theory Of Public Space," by George Baird

February 7

"Forms Of Settlement, by René Davids And Christine Killroy

December 13

"Structural Creations In Timber," by Julius Natterer

### MasterCard Discount A Terrific Deal!

# 1.85%

The CAB C is pleased that a new benefit is

now available to all our members. The Bank of Montreal MasterCard merchant financial institutions in BC (i.e., Richmond Savings Credit Union, Bank of BC Hong Kong Bank of Canada, Interior Savings Credit Union, and Pacific Coast Savings Credit Union) are now offering a preferred merchant discount rate of 1.85%. This is a great opportunity for members who are already MasterCard merchants, and is an opportunity for those who are not, to possibly enhance sales and customer service through offering MasterCard. If you are a CAB C member who currently accepts MasterCard through one of the above institutions and wish to take advantage of the 1.85% discount rate, complete the form and forward it to the CAB C. For more information contact Lisa Chapman at the Bank of Montreal at 665-7465.

### MasterCard Discount A Terrific Deal!

BANK OF MONTREAL OR AFFILIATE BANK MERCHANT NUMBER

TRADE NAME

ADDRESS

CONTACT NAME

TELEPHONE

DEPOSIT/FINANCIAL INSTITUTION

ACCOUNT NUMBER

#### Return To:

Crafts Association of British Columbia  
1386 Cartwright Street, Granville Island  
Vancouver, British Columbia V6H 3R8

# CRAFT CALENDAR

## EXHIBITIONS

### MUSEUM OF CIVILIZATION

Innovative utilitarian work preferred. Immediate need for work in metal, wood, basketry, or textiles. Submit name, address, phone number, and list of current representation. This call has been made through the Canadian Crafts Council, which requests a copy of your letter of submission be sent to the CCC, 189 Laurier Ave. E., Ottawa, ON K1N 6P1. 613-235-8200, FAX 613-235-7425. Contact Penny Troitier, Manager Commercial Programmes, Canadian Museum Of Civilization, P.O. Box 3100, Stn. B, Hull, PQ J8X 4H2.

### RAKOW COMMISSION: THE CORNING MUSEUM OF GLASS-INTERNATIONAL

Ongoing. Works in glass for the museum's permanent collection. No formal applications procedure; send résumé and slide of glass art to be considered. Contact Susanne Frantz, Corning Museum Of Glass, 1 Museum Way, Corning, NY 14830-2253, 607-937-5371.

### WALT DISNEY ATTRACTIONS INC.

Ongoing. Canadian craftspeople needed to display, do demonstrations, and sell their work at the Canadian Pavilion in the Epcott Centre. Please send photos and a résumé to Chuck Williams, Merchandise Buyer, Walt Disney Attractions Inc., Box 10000, Lake Buena Vista, Florida, 407-345-7705.

## MARKETPLACE

### Souvenir Boutique On Parliament Hill

is seeking to expand the collection of items it offers to MP's and visitors. Products should reflect Canada's Parliament or its provincial and territorial counterparts; be 100% Canadian made, and meet current environmental standards. Packaging should be fully bilingual. Contact Guyanne L. Desforges, Public Information Office, Room 300 East Block, House of Commons, Ottawa, ON K1A 0A6, 613-992-4793.

### Photographer available to document

your work for portfolio or reproduction. Prints, slides, 4x5 and 8x10 transparency formats available. Rates available upon request, call Holly Hames 604-252-6102.

### The Cafe International—Located in the

Emerson Cultural Centre, The Cafe has a display area for Canadian artists. Display is free with certain restrictions. Contact Andy Hassanali, 808½ N.Block, Bozeman Mt 59715, 406-586-6716.

### For Sale—Leclerc Colonial 45" Loom.

This loom can be a 4 harness counter-balanced loom with adjustable harness heights. \$1,350. O.B.O. 604-946-5939.

### For Sale—Bookbinding equipment,

materials, and high quality leather suitable for a variety of craft work. Enquiries evenings 926-2706.

### For Sale—AVL Loom, 48", 4 Harness

Dobby Convertible Loom with automatic cloth storage system, fly shuttle, and auto advance. Includes delivery and set-up in Lower Mainland area. \$5,000. 872-4965.

### Candle Business For Sale—9 years in

business. All equipment, extensive client list, and training included. Contact Chris at 792-3167.

No room to pursue floral arrangements hobby. Loose silk and dried flowers, containers and arrangements available at reasonable prices. Phone 604-433-4331 (days only).

### The Bronze Gallery—Seeks wall hang-

ings to complement sculpture shows. Send slides to Sutomi, The Bronze Gallery, 227 Granville St., Vancouver, BC 604-737-8867.

### Banff Visual Arts—Time and space for

visual artists. Summer, winter, and fall terms. Financial aid available. Contact The Banff Centre, PO Box 1020, Banff, AB T0L 0C0 403-762-6180

### Canadian Craft Museum Shop—We

invite jewellers from across Canada to submit slides or 2-3 samples of your work for consideration by the selection group. Please send to the attention of the Canadian Craft Museum Shop, Cathedral Place Courtyard, 639 Hornby St., Vancouver, BC V6C 2G3.

### Van Dop & Associates—seeks Cana-

dian craft for 3 galleries. Interested in all mediums: clay, ceramic, glass, fibre, metal, and mixed media. One of a kind and production work. Now accepting applications for our upcoming Christmas Show "Spirit Of The Season." Forward slides/photos, artist's statement, and updated CV to Trudy Van Dop, 421 Richmond St., New Westminster, BC V9L 4C4.

### For Sale—23 lbs shorn llama fibre,

uncarded. Colours: off-white, light grey, red-brown, black. Lot price: \$300. Phone 467-8555.

### The Craft Gallery Of The Ontario Crafts

Council—Submit proposals, slides, and resume with SASE to Dale Barrett, Curator, The Craft Gallery, Ontario Crafts Council, Chalmers Building, 35 McCaul St., Toronto, ON M5T 1V7, 416-977-3551.

## CRAFT CALENDAR

Contact Patricia Hansen

TEL: 687-6511 FAX: 687-6711

Next Deadline: January 7

Display Ad Rates:

1/6 page-\$35 1/2 page-\$90

1/4 page-\$45 Full page-\$175

Display ads must be provided camera-ready. Call for details.



CRAFT CONTACTS

# CRAFT CALENDAR



**The Canadian Musicians Association**  
For **Cooperative Housing** is conducting a survey to assess the housing needs of Senior Artists. If you consider yourself a professional or recreational Senior Artist and would like to assist the project or respond to the survey, contact 732-0188, FAX 734-7047.

## GRANTS & AWARDS

**CANADA COUNCIL**  
**Arts Grants "A"** - Cover living expenses, project costs, and travel expenses for established artists who are continuing their creative work. To be eligible, you must have gained critical attention and recognition for work over a sustained period of time in exhibitions at the national or international. "A" grants are worth up to \$31,000, but visual artists may request up to \$1,000 if extra material costs are anticipated. **Deadlines:** Apr. 1, Oct. 1. Results are announced approximately 12 weeks after closing date. Info: Myriam Mérette, 1-800-263-5888, ext. 4094.

**Arts Grants "B"** - Up to \$17,000 cover living expenses, project costs, and travel expenses for artists who are pursuing their creative work. To be eligible, you must have worked full-time at your art for at least one year (following your studies), have completed a body of individual work, and have participated in at least one solo or several group, professional exhibitions. They are now juried three times yearly. **Deadlines:** Jan. 15, May 15, Sept. 15. Info: Myriam Mérette, 1-800-263-5588, ext. 4094.

**Short Term Grants** - If craftspeople meet the eligibility criteria for "A" and "B" grants and need a short period of time to pursue creative activities or to work on a specific project, they may apply for a grant up to \$4,000. Additional travel allowance of up to \$2,800 possible. **Deadlines:** Mar. 15, July 15, Nov. 15. Info: Jacques Doyon, 1-800-263-5588, ext. 4092.

**CANADA COUNCIL**  
Ongoing awards to artists through the Jean A. Chalmers Fund for the Crafts: Criticism and Curating, Project and Travel Grants, Visual Art Grants, Contact The Canada Council, P.O. Box 1047, 350 Albert St., Ottawa, ON K1P 5V8 or call 1-800-263-5588.

## COMMONWEALTH SCHOLARSHIPS

The following countries offer Canadian citizens scholarships for postgraduate level in the arts and other disciplines. **Deadline for Australia and New Zealand is Dec. 31.** Contact International Council for Canadian Studies, 325 Dalhousie St., Ste. 800, Ottawa, ON K1N 7G6, 613-789-7828.

## POLLOCK-KRASNER FOUNDATION

Financial assistance to artists of recognized merit working in paint, sculpture, craft, or mixed media. No age or geographic limitations. Grants awarded throughout the year, vary in size and length according to each artist's circumstances. Contact The Pollock-Krasner Foundation Inc., 725 Park Ave., New York, NY 10021, 212-517-5400.

## TRAINING INITIATIVES PROGRAM

Supports training projects and requests for professional development training in cultural sector, administered by the Canadian Conference of the Arts. Organizations, artists and cultural workers wishing to mount training projects and artists seeking support for professional development may apply. Contact Susan Annis or Jean-Philippe Tabet, Canadian Conference of the Arts, 189 Laurier Ave. E., Ottawa, ON K1N 6P1, 613-238-3561.

## CRAFT GALLERY

The Ontario Craft Council accepts proposals with slides, resume, and SASE. Contact Dale Barrett, Curator, The Craft Gallery, Ontario Arts Council, Chalmers Bldg., 35 McCaul St., Toronto, ON M5T 1V7, or call 416-977-3551.

**CREATIVE CRAFT FAIRS™**  
**1996 Show**  
Victoria, B.C.  
**Nov. 7-10**

Contact  
**Terri Heit**  
977 Kenwood Terrace,  
Victoria B.C.,  
V8Y 1A5  
**1-604-658-2901**

*Food, Music, Art,  
Crafts - Demos,  
Prizes.*

PEARKES  
3100 THILLICUMRD.

**SHEILA HUGH MACKAY FOUNDATION**  
Promote public knowledge, participation in and appreciation of Canadian arts and crafts and their importance in the cultural heritage of Canada. Individual grants not to exceed approx. \$1,000. **Deadlines** are Apr. 30 and Oct. 31. Contact Sheila Hugh Mackay, Box 737, Robbsey, NB E0G 2W0, 506-847-5322.

**OAC Individual Crafts Grants**  
Up to \$10,000 annually for professional craftspeople working in clay, fibre, glass, leather, metal, resins, and wood. Craft grants assist with purchase of special tools, materials, equipment, and studio costs; encourage creative development; identify and nurture new talent. **Deadlines:** Apr. 1, Oct. 1. To obtain an application, form contact: OAC Visual Arts Office, 151 Bloor St. W., Ste. 500, Toronto, ON, 416-977-3551.

# CRAFT CALYNDAR

## CANADIAN NATIVE ARTS FOUNDATION

A nationally registered charity established to actively assist talented aboriginal artists by providing financial assistance for education and training initiatives in the arts, including performing, visual, crafted, media, literary, and graphic arts. Deadlines Mar. 31 and Sept. 30. Contact CNAF, 77 Mowat Ave., Ste. 508, Toronto, ON M6K 3E3, 416-588-3328.

## GOEBEL CANADA

Annual international awards for porcelain sculpture totalling \$25,000. Contact Marcel Brandstat, President, Goebel Canada, 1200 Carnforth Road, Toronto, ON M4A 2K7.

## CHALMERS FUND FOR CRAFT

Assists non-profit organizations to undertake projects that contribute to the advancement of crafts in Canada. The fund provides partial funding on a one-time basis. The 3 categories of assistance include: Research Assistance, Special Projects Assistance, and Publications Assistance. Info: Marianne Hegyveit, 1-800-263-5588, ext. 4269.

## INDEPENDENT PROJECTS FELLOWSHIPS

John Simon Guggenheim Memorial Foundation awards one-year fellowships (e.g. US \$26,500) for artists to pursue independent projects. Applicants must be US or Canadian citizens. Contact: The John Simon Guggenheim Memorial Foundation, 90 Park Ave., New York, NY 10016 or call 212-687-4470.

## ARTS AWARDS SERVICE

The Canada Council offer 4 types of grants to Canadian artists of all world cultures who are recognized as professionals by their peers and who have a history of public presentation. Deadlines vary according to discipline. For a free brochure contact: Arts Awards Service, The Canada Council, P.O. Box 1047, Ottawa, ON, K1P 5V8, 800-263-5588 or FAX: 613-566-4342.

## ARTS APPRENTICESHIP

Grants are available up to a maximum amount of \$15,000 for a 10 month training period or \$1,500 per month. For information contact: Program Officer, Arts Apprenticeship Component, Heritage Cultures and Languages Program, Dept. of Canadian Heritage, 365 Laurier Ave. West, Ottawa, ON K1A 0M5, or phone 819-953-9385.

## CONFERENCES

### ANNUAL ARTIST'S RETREAT

**FEB. 5-10, 1996**  
Mauna Kea State Park, Island of Hawaii. \$220 per person includes 5 nights lodging and all meals. Focusing on Hawaiian plant fibres and their uses (paper, tapa, and lei making). SASE for more info: Marilyn Wold, PO Box 5202, Aloha, OR 97006, 503-641-2294.

### CLOTHING: AN INTERWEAVE FORUM

**MARCH 11-17, 1996**  
A seven day forum focused on handwoven cloth and clothing construction. Special workshops in surface design applications for woven cloth; cloque and devore; fabric finishes; expressing the most with the simplest structures; the art of overtwist; materials explorations; from idea to finished fabric; pattern selection and adaptation; garment finishings that make the difference. Contact Marilyn Murphy, Interweave Press, 201 E. 4th St., Loveland, Colorado, 1-800-272-2193.

## MARKETS & FAIRS

### CALL FOR ENTRIES

**Explorations In Wood '96-A** juried exhibition to be held at the Maltwood Art Museum And Gallery, Jan. 28 to Mar. 22, 1996. Contact The Vancouver Island Woodworker's Guild, Victoria, BC, 604-592-4938.



**1215 MAIN STREET SMITHERS B.C.**  
since 1987

Inviting artists and craftspeople looking for new markets to send work North We take items on consignment or buy outright on occasion. We are seeking seasonal handmade decorations and gift items for our big Christmas season. Well established. References available

Contact Tenley  
847-9871

or write Box 572  
SMITHERS B.C. V0J 2N0

### CALL FOR ENTRIES

**Convergence 96-**The Portland Handweavers Guild invites artists working with wool felt, handmade or commercially made, to enter this juried exhibit of felt hats and foot coverings, July 17-21 at the Oregon Convention Center. Deadline: Feb. 1. Contact Convergence 96, Exhibits, PO Box 3378, Portland, OR 97208-3378.

### CALL FOR ENTRIES

**Vancouver Craft Market**—Now accepting applications for 1995 Original Vancouver Craft Market at Van Dusen Gardens, Dec. 8-10, and the Second Annual Classic Christmas Craft Fair Nov. 9-12 at the Plaza of Nations. To apply contact Simone Avram, VCM Promotions Ltd., 8540 Demorest Dr., Richmond, BC V7A 4M1 or phone/fax 275-2724.

# CRAFT CALENDAR

~~**Craft Works**—For a unique selection of holiday gift ideas, the Community Arts Council Of Vancouver presents its tenth annual holiday season craft fair from Nov. 28 to Dec. 23 at the CCA gallery at 837 Davie St., Vancouver, BC.~~

#### ~~CALL FOR ENTRIES~~

~~**The Quilt Project**—Women's Art Resource Centre seeks submissions – a collection of diverse quilts by Canadians to be displayed in a permanent location. Submissions should document the lives, beliefs, and travels of the artists or their families. Contact: The Quilt Project, WARC, 309-394 Euclid Ave., Toronto, ON M6G 2S9 416-324-8910.~~

#### **CALL FOR ENTRIES**

**Images & Objects XIV**—BC's largest annual juried exhibition is calling for entries from artists working in all media. There will be 13 regional qualifying shows throughout BC between Feb. and Mar., 1996. Artists who have work selected will receive subsidies to attend the exhibition and 3 day conference at the BC Festival of the Arts in Pentiction, May 22-26. Contact your local Community Arts Council or Francesca Lund, Assembly of BC Arts Councils, 201-3737 Oak St., Vancouver, BC V6H 2M4, 604-738-0749.

#### **CALL FOR ENTRIES**

~~**The Cultural Human Resources Council** invites training proposals for the 1996-97 year. CHRC purchases training for artists and cultural workers under its Training Initiatives Program, providing access to skills upgrading for those who cannot find funding support through the Canada Employment Centres' regular programs, and facilitating quality training initiatives within the cultural sector. The deadline for receipt by CHRC of proposals is Dec. 15. Contact Jean-Philippe Tabet, Director of Training, Cultural Human Resources Council, 613-565-7956, FAX 613-565-7022. E-mail CHRC@magi.com.~~

#### **CALL FOR ENTRIES**

~~**The Homer Watson House And Gallery** invites craftspeople to submit their work. Deadline: Jan. 31 for 1997 shows. Please send résumé, artist's statement, and 12 slides to Homer Watson House And Gallery, 1754 Old Mill Rd., Kitchener, ON N2P 1H7, 519-748-4377.~~

#### **CALL FOR ENTRIES**

**Pioneer Square Studio/Gallery**—Reviewing work of new and emerging visual artists for first Thursday gallery walk exhibit. Deadline: unspecified. SASE for info to: ACE Studios/Exhibit Review, 619 Western Ave., Box #16, Seattle, WA 98104.

#### **JURIED SHOWS**

~~**Christmas, 1995** Dec. 3-7, St. Albert High School, St. Albert~~  
~~**Spring, 1996** May 6-7, Akinsdale Arena, St. Albert~~  
Contact: Quality Craft Show, 12 Wheatstone Crescent, St. Albert, Alberta T8N 3G5, or phone Wendy 403-459-2521 or Shirley 403-458-7979, or FAX 940-7934.

#### **CALL FOR ENTRIES**

~~**Labelmaking Today**—Mar. To Oct., 1996. Canadian contemporary handmade lace. Deadline: Jan. 25. Please submit labelled slides or photographs of up to three recently completed works. Include materials, technique, date, title, dimensions, and a SASE to The Museum For Textiles, 55 Centre Ave., Toronto, ON M5G 2H5, 416-559-5321.~~

#### **WORKSHOPS/EDUCATION**

**Guild Of Canadian Weavers** offers a self-guided home-based text program leading to a Masterweaver certificate, 4 bulletins per year, access to a library of textile books and videos, scholarships, travelling exhibits, and more. Contact Rosalie Williams, GOCW, 9102 Cherry Lane, Vernon, BC V1B 1V9.

Seattle Arts Commission Request to be added to mailing list for Seattle Arts Newsletter and ask to receive any current public art prospectus. There is no charge for newsletter. 100-221 First St., Seattle, WA 98119-4223, 206-684-7171.

**Needleworks** workshops March 14-17 in quilting, surface design, polymer clay, dollmaking, beading, crochet, knitting, and handmade paper with nationally known instructors. Coupeville Arts Center, Box 171LC, Coupeville, WA 98239, 360-678-3396.

**Pyramid Bronze Works Ltd.**  
**P.O. Box 1755, Station A**  
**Kelowna, BC V1Y 8M3**  
**(604) 763-8239**

- Quality fine art castings in Everdur bronze
- From mold making to patinas
- Lost wax process with ceramic shell
- Quarterly weekend bronze casting workshops
- Custom design consultation
- A foundry run by sculptors for sculptors

March / April

# ~~WESTERN CRAFTS~~

## ~~8 Successful Years of Craft Fairs!~~

~~Craft Market venues  
in Nov. and Dec.:~~

- ~~• VAN DUSEN GDNS.  
(Vancouver)~~
- ~~• GLENEAGLES G.C.  
(Vancouver)~~
- ~~• OAK BAY BEACH  
HOTEL (Victoria)~~

~~For info call Lyn at~~

~~(ph) 739-9002~~

~~(fax) 739-9004~~

## SET UP BUSINESS IN MAYFAIR

Our Kiosk  
Leasing Program  
is ideal for  
your specialty

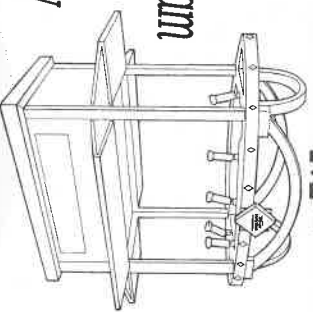

### RENT OUR KIOSK FOR YOUR BUSINESS

Our Kiosk Leasing Program provides endless opportunities for profit and exposure.

### WE'LL WORK WITH YOU TO BE A SUCCESS

Our merchandising specialists and temporary tenant literature will help you achieve maximum results.

Choose Mayfair Shopping Centre  
as your new gateway to success in business.

# MAYFAIR

SHOPPING CENTRE

Administration Office #221 - 3147 Douglas Street  
Victoria, B.C. V8Z 6E3 Phone: (604) 383-0541 Fax (604) 381-0542