

CRAFT CONTACTS

October, 1995 • ISSN 0319-8873

Craft Contacts is published
six times annually by

cabc

Crafts Association of British Columbia
1386 Cartwright Street, Granville Island
Vancouver, British Columbia V6H 3R8
TEL: 687-6511 FAX: 687-6711

*The Crafts Association of British Columbia
promotes the development and appreciation
of British Columbia artisans and their crafts.*

EXACTLY!

Interdisciplinary projects such as this ceramic tile painted mural is just one example of what the organizers of *Enriching Our Environment: Craft And Architecture* have in mind. The CABC's symposium will address issues surrounding the integration of craft, design, and architecture for public and private spaces. See page 2 for more information. 

INSIDE...

- "Enriching Our Environment" 2
 - Nature Of Things 4
 - Computers In Textiles 5
 - Candlesticks at Terminal 3 9
 - Craft Calendar 10
- Plus more of our regular features!

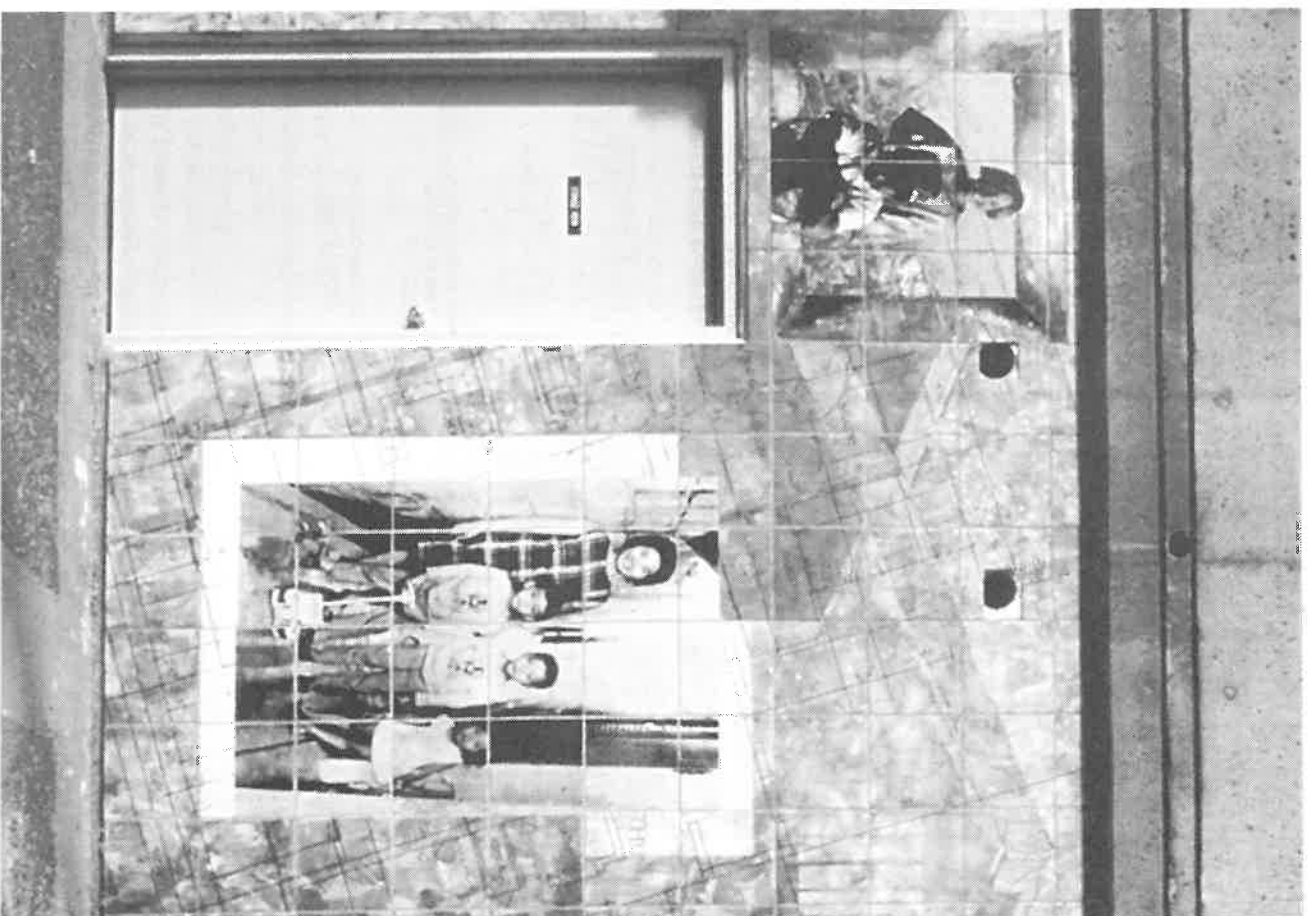

Detail from a ceramic painted tile mural for a housing project for single mothers, by Nhan Duc Nguyen, 1993

cabc

Crafts Association of British Columbia
1386 Cartwright Street, Granville Island
Vancouver, British Columbia V6H 3R8
TEL: 687-6511 FAX: 687-6711

BOARD OF TRUSTEES

Sheryl Adley	Margaret Klajpert
Ilona Barakso Lindsay	Patti Koenig
Aika Gladwin	Jennifer MacMillan
Laura Groos	Eric Allen Montgomery
Valerie Jones	Ruth Scheuring
Erika Justman Rowell-VP	Trudy Van Dop-Pres.
Shirin Karmali	Grace Van Der Brink

STAFF

Crafthouse Manager: Jo Darts
Editing and Production: Peter Ross.
Keywords Design
Bookkeeper: Ann Wray
Office Administrator: Fiona Macleod

REGIONAL REPS

Victoria	Okanagan-Boundary
Meira Mathison	Peter Flanagan
R.R.1, Pearson College	R.R.1, Site 5, C-22
Victoria, B.C.	Peachland, B.C.
V9B 5T7	V0H 1X0
478-5591	Home - 767-2540
727-9463	Work - 737-2010
East Kootenay	Lillooet-Thompson
Suzanne Ashmore	Chuck St. John
P.O. Box 91	General Delivery
Wasa, B.C.	Phanant Lake, B.C.
V0B 2K0	V0E 3E0
422-3547	573-3392
Central Kootenay	Mid-Vancouver Island
Angelika Werth	Allan Burgess
801 Park Street	R.R.1, Site 38, Comp. 12
Nelson, B.C.	Comox, B.C.
V1L 1H2	V9N 5N1
399-4262	339-6776
Mid-Vancouver Island	
Ted Jolda	
122 West Fern Road	
Qualicum Beach, B.C.	
V9K 1T5	
752-1122	

VOLUNTEERS

Melanie Boyle	Kandice Kwok
Martha Casey-Knight	Christine Lawrance
Holli Facey	Charlotte Lightburn
Linda Hale	Elizabeth Owre
Amy Hinrichs	Lori Prest
Shelley Ikegami	Masumi Wada
Jane Irwin	

SPONSORS' HONOUR ROLL

Without the dedication and support of our sponsors, the Crafts Association of British Columbia would have to expend valuable resources on many non-crafts related activities. We really appreciate the commitment these donors make to the CABC.

**THE PRINTING HOUSE LTD**



**BEAUTIFUL BRITISH COLUMBIA Gift Shops**

**ARCA BELLA**

FINE CRAFTS AND COLLECTIBLES



Canadian

Canadian Airlines International



Province of British Columbia
Ministry of Small Business,
Tourism and Culture

WESTERN LIVING

Defy 94 Challenge 94

OCEAN

CMHC SCHL

MacKenzie HUISKYA, Brewer
STEVENSON COOKING
Breweries and Salubria

ROBERT SCHINDLER DESIGN

Green College
University Of British Columbia

Margaret Klajpert
Textile Studio

Alcan Lectures On Architecture

Architectural Institute
Of British Columbia

Award Magazine

Design BC

Emily Carr College Of
Art And Design

Interior Designers' Institute
Of British Columbia

Terra Bread

We gratefully acknowledge the financial support of the Government of British Columbia through the Ministry of Small Business, Tourism and Culture.

Opinions expressed in Craft Contacts are those of the authors, and do not necessarily represent that of the Crafts Association Of British Columbia.

THE PRESIDENT'S MESSAGE



BY TRUDY VAN DOP—On behalf of the Board Of Directors and CABC members, I would like to extend our thanks and appreciation to the BC Government, Ministry Of Small Business, Tourism And Culture for its support for our *Enriching Our Environment: Crafts And Architecture* symposium, and the Art At Terminal 3 Show - Candlestick Exhibition in Toronto. In addition, I would like to extend our thanks to the City Of Vancouver for their financial support. We encourage and invite you to attend on Oct. 28-29 and learn more about how we can work toward attaining a mutual understanding and working relationship with the craft, design, and architecture communities.

An mentioned in my previous message (September), we face challenging

times, but I believe challenges bring positive growth and change. Like many Craft councils across Canada, we realize that we must look at the programs that we offer with the viewpoint that they must be on a cost recovery basis. Our aim over the next years will be to develop our programs and our association in this direction. We are thankful to our sponsors, advertisers, members, City Of Vancouver, and BC Government for their ongoing support.

Our first program objective is with Crafthouse. Over the past years Crafthouse has been dependent on our association to make up its shortfall. We have a talented group on our Retail Committee, co-chaired by Jennifer MacMillan (Beautiful BC) and Ailki Gladwin (Ailki Gladwin & Associates). We have received many suggestions from our members about ways to increase our revenues. With everyone's support and contribution, we believe that we can achieve our goal of having

Crafthouse become self sufficient. We look forward to a very successful holiday season and attaining our goal of being the Number 1 location for craft! Fiona Macleod, in her new role as Office Administrator, is keeping our association running smoothly and has begun to update the Resource Guide. If you have any suggestions or would like to advertise, please give her a call. Our resource guides have proven to be a very valuable source of information. We are taking pre-orders, so call to reserve your copies.

We have a number of opportunities to promote our organization to the public and we request you look at your calendar and volunteer for a shift at either Circle Craft, Nov. 21-25, Vancouver Trade & Convention Centre, Vancouver, or at CraftWorld, Oct. 27-29 at the Cloverdale Fairgrounds. Call the office and leave your name and number. Thank you for your continued support. ☺

NEW AND RENEWING MEMBERS

Ernestine Allan	Lesley Richmond
Zuzana Bojnanska	Randall Roach
Cynthia Farnsworth	Kathy Robertson
Jane Garcia	Elsa Schamis
Ailki & Don Gladwin	Louise Slobodan
Ulrike Gruetz	Joe Soliarz
Terri Heit	Helen Suoni
Brad Hudson	Ingeborg Thor-
Michael Lambert	Larsen
Dar McDowell	Mary Ursuliak
Tara McKendry	Linda Varro
Kaye Miller	Curtis Walker
Enilio Moras	Heather Wilson
Wayne Ngan	Tina Witt
Sean Rea, Crafters Marketplace	Lisa Wojcik

Join The Crafts Association Of British Columbia

General \$47 Student/Senior \$30 Family \$62
 Affiliate \$65 CABC Patron \$150

Benefits Of Membership:

- ☆ *Craft Contacts* Monthly Newsletter
- ☆ Resource Centre
- ☆ Portfolio Registry
- ☆ Video Lending Library
- ☆ Yearly Scholarship Awarded
- ☆ 10% Discount In Crafthouse Gallery/Shop

My donation of \$ _____ is enclosed

NAME _____

ADDRESS _____

CITY _____ PROVINCE _____

POSTALCODE _____ PHONE _____

Yes, I would like to volunteer!
 Send cheque to: CABC,
 1386 Cartwright St., Vancouver, BC
 V6H 3R8

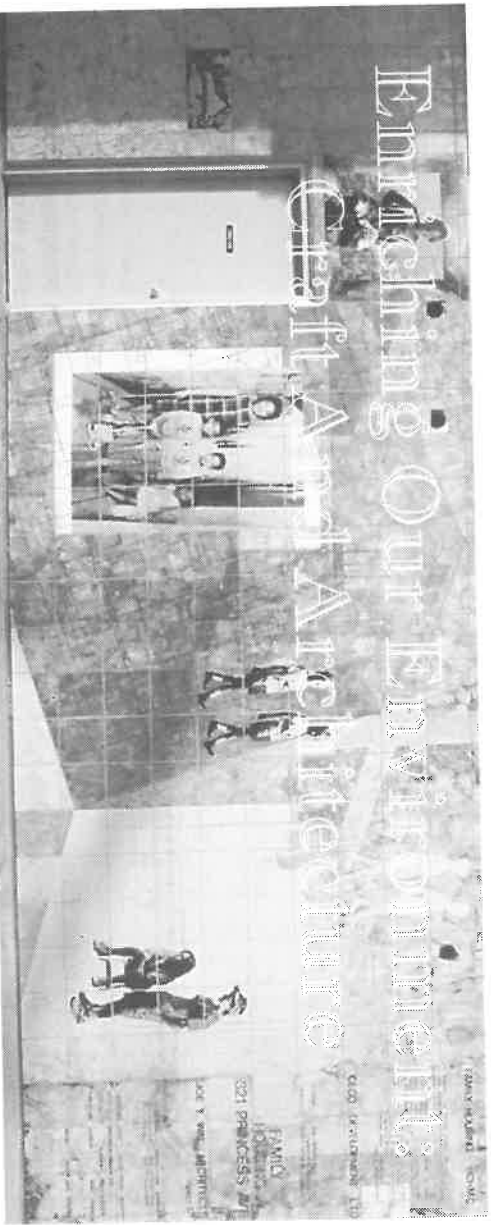

Ceramic painted tile mural for a housing project for single mothers, by Nhan Duc Nguyen, 1993

Private and public space are realms which shape our perceptions of environment. Craft, design, and architecture, on different levels, influence our perceptions of these spaces. By bringing professional representatives from these three communities, each with their own perspectives, insights, and experiences, "Enriching Our Environment: Craft And Architecture" is designed to help promote a greater understanding on how these disciplines interact with one another and where collaborations can and do occur. Delegates will be part of a discussion where working together to help clarify and define our understanding of collaborative access will open doors to future opportunities and learning.

This two day symposium, presented by the Crafts Association Of British Columbia will be held Saturday, October 28 at the Emily Carr Lecture Theatre in the Patkau building, and Sunday, October 29, when delegates will visit artists' studios on Granville Island and 1000 Parker Street, an artists' complex.

Saturday Morning

Saturday's schedule will be comprised of two discussion panels. The morning panel beginning at 10:30 am involves architects, craftspeople, and clients. It will explore the role of the patron/client in building, the role of the architect and the role of the craftsperson. Based on the principle that fine building involves fine craft, any building is a result of many people's shared skills, vision, and faith. Through case studies, this panel will discuss the success and difficulties of craft and architecture working together towards fine building.

Participants

Taking part in this panel are Kim Smith and Bo Hellmwell, founders of Blue Sky Architecture who are internationally recognized for their buildings and designs which exhibit a strong commitment to modern technology and natural materials in harmony with sites and their surrounding environments. John Grunewald, a craftsperson who specializes in fine wood and milled work and whose work has been commissioned for residences designed by Blue Sky Architecture. Joel Berman, founder of Joel Berman Glass Studios, an internationally recognized glass artists whose work is represented in corporate and residential installations. He understands the importance of collaboration in the design process in order to achieve outstanding results.

Saturday Afternoon

Delegates will reconvene at 2:00 pm for the afternoon panel. Discussion will focus on issues surrounding the successful integration of craft, design, and architecture. Moderator Isabel Corral will open the discussion with an overview of contemporary concerns regarding these issues. Isabel is a private consultant specializing in urban related areas of heritage and innovative community planning. Also involved are Lynn Basa, Director and Curator of the Public Art Program at the University Of Washington, who has had two parallel careers for the past 15 years as both a fibre artist and public art curator. Peter Cardew, an architect whose award winning projects include the Belkin Art

Gallery at the University Of British Columbia 1995, Stone School, Stone BC 1989-93, and CN Pavilion, Expo '86. Alda Pereira, an interior designer with her own practice in Vancouver which specializes in both residential and commercial interiors. Her work has received awards from the Interior Designers Institute Of BC and has been featured in several publications. Don Vaughan, a landscape architect and sculptor with broad experience in public park development, community revitalization, and planning.

Reception

The varied concerns and interests of each discipline and the participants will be accommodated through the morning and afternoon panel discussions. Wrapping up Saturday's events is an evening reception starting at 5:00 pm at Craithouse. Delegates and panelists are invited to attend and to relax and reflect on their day's experiences.

By focusing on the practical and theoretical issues surrounding the successful integration of craft, design, and architecture in private and public spaces, this symposium will illustrate how interdisciplinary collaborations of this type are functional, feasible, and immensely valuable to the aesthetic, architectural, and social environments. "Enriching Our Environment: Craft And Architecture" will inform and affect our understanding of the aesthetic harmony that collaborations between these three communities bring to our daily lives.

To register for this event, fill out the accompanying registration form on page 3 and mail back to the Crafts Association Of British Columbia.

OUR ENVIRONMENT

Craft AND ARCHITECTURE

PANEL DISCUSSIONS - OCTOBER 28, 1995 - EMILY CARP LECTURE THEATRE

Panel 1: Working Together - 10:30 am

Through case studies this panel will explore the role of the patron/client, the architect, and craftsman working together towards fine building. Panelists: Kim Smith & Bo Hellikell - Blue Sky Architecture, Joel Bertram - glass artist; John Grunewald - craftsponsor; Anne Popoma - President, Whistler Centre Of Business And The Arts.

Panel 2: Collaborative Access - 2:00 pm

This panel will focus on issues surrounding the successful integration of craft, design, and architecture. Panelists: Isobel Corral - Moderator; Lynn Bosa - director and curator of the Public Art Program at the University of Washington Medical Centre; Peter Cardew - architect; Alida Pereira - interior designer; Don Vaughan - landscape architect/sculptor.

RECEPTION - OCTOBER 28, 1995 - CRAFTHOUSE: GRANVILLE ISLAND 5:00 PM

Architects, designers, and craft artists.

GUIDED STUDIO TOURS - OCTOBER 29, 1995

Granville Island in the morning; 1000 Parker Street in the afternoon.

Enriching Our Environment: Craft And Architecture is designed to foster a greater understanding and collaborative access between the communities of craft, design and architecture.

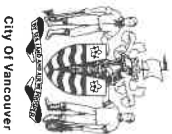

City of Vancouver



Province of British Columbia
Ministry of Small Business,
Tourism and Culture

Fees (Including GST)

Full Symposium Package

CABG Members: \$32.10 Others: \$38.52

Panel Discussions (Each: CABG Members: \$16.05, Others: \$19.26)

Working Together Collaborative Access

Studio Tours (Each): \$5.35

Granville Island 1000 Parker Street

NAME _____ PHONE NUMBER _____

STREET _____ CITY & PROVINCE _____ POSTAL CODE _____

VISA/MASTERCARD NUMBER _____ EXPIRY DATE _____

SIGNATURE _____

VISA MASTERCARD CHEQUE (PAYABLE TO CABG)

To pre-register
cabc
1386 Carwight St., Granville Is.,
Vancouver, BC V6H 3R8
604-687-6511 (fax) 604-687-6711

To Be Charged \$ _____

Full fee must accompany
registration form.

Resource Guide 1996/97

Attention Members!!

We are currently compiling information for our next Craftsper-son's Resource Guide to B.C. If you have any updates for the following sections, please fax

Fiona Macleod the information

at (604)687-6711, or phone
(604)687-6511 on Tues. - Fri.

1. Retail Outlets
2. Native Art & Retail Outlets
3. Craft Fairs
4. Suppliers - this is a big area that needs work. If crafts-people know of suppliers that would like to be listed, please make sure they give me a call.

TEXTILE ARTS

The Textile Arts Program at Capilano College will be offering two new courses entitled "Professional And Business Skills In Arts And Crafts," and "Design And Concepts In Cloth." Both courses will be held in the evening and will start in January. There will also be some spaces available in advanced weaving and surface design. For more information contact the Visual Arts Office at Capilano College, 2055 Purcell Way, North Vancouver, BC V7J 3H5 604-984-4911.

Also

The surface design group of the Vancouver Guild Of Fabric Arts is holding a special surface design weekend, Oct 28-29 in Room 2001 of the Arbutus Building at Capilano College. Short demos, slides and presentations will be offered. Contact Peggy Schofield for registration 263-5590.

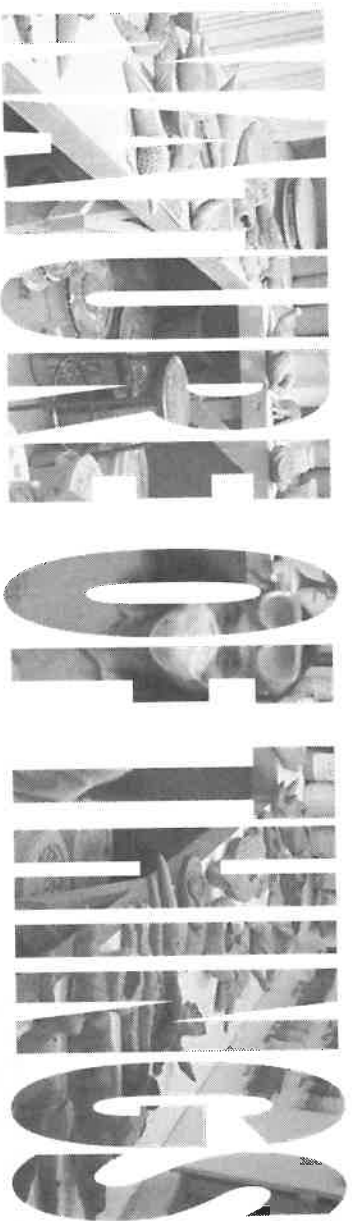

THE POTTERS

Sadashi Inuzuka combines New York confidence with West Coast inspiration at the Richmond Art Gallery

BY MELANIE BOYLE—Clay is usually not the first thing that springs to mind when you think of New York City, unless you have discovered Greenwich House Pottery. This past summer, Vancouver-based ceramic artist Sadashi Inuzuka

did just that. As an invited artist-in-residence he

worked for three months at Greenwich House Pottery, an historic institution which, over its eighty year history in the Village, has introduced ceramic artists through

residencies, workshops, and classes to New York.

Using all available facilities, materials, support, and his own energies,

Inuzuka managed to squeeze out of his limited time and studio space at Greenwich House Pottery over 600 sculptural works. These form his forthcoming installation entitled *Nature Of Things* at the Richmond Art Gallery, Oct. 19 to Nov. 20.

The Early Years

Inuzuka is known for his large site-specific ceramic installations, though he began his career in ceramics only after immigrating to Canada from Japan in 1981. He discovered his passion for working with clay while at Emily Carr College Of Art And Design, and from there began to explore the emotional and physical potential of a raw handling of large-scale ceramics. Inuzuka's ambitions and curiosity led him to Cranbrook Academy Of Art in Michigan

where he completed his MFA in 1987. For the next six years from his Toronto studio, Inuzuka built his reputation on making whole environments that combined ceramics with natural elements of grass, water, and

stones.

I strongly believe if I work sincerely, put all my energy into it, that's how I meet lots of good people who help my project. But I think if my intention is not true then no one will help me.

When Inuzuka was invited to work at Greenwich House Pottery, he did not know what to expect nor exactly the scale of the project he would undertake. As the residency unfolded his project took shape and, adapting his work to suit the circumstances, he produced not big sculptures, but hundreds of smaller ones.

sculptures, but hundreds of smaller ones.

Moving Problems

How to get them out of New York and back to Canada became the big question, for both the artist and an unpaid Greenwich House staff. Inuzuka says, "From the beginning I wanted to make lots of them but never thought of after, only thought of process. I strongly believe if I work sincerely, put all my energy into it, that's how I meet lots of good people who help my project. But I think if my intention is not true then no one will help me. That's important."

Happily, with the negotiating efforts of the Richmond Art Gallery, CP Rail system agreed to sponsor the exhibition and provide transportation of the works, twenty-five crates in all, and not one piece broke in transit!

Nature Of Things is made specifically for the large interconnecting galleries at

The Richmond Art Gallery. Each of the over 600 low-fire earthenware pieces that make up this installation is unique in shape, texture, colour, and form and ranges from 6 inches to 3 feet in size.

Nature Of Things focuses on the physical experience of clay and, in a new direction for the artist, the obsession with the object and its making. Since these pieces, as Inuzuka says, "combine fundamental ideas deep inside me with the process of making," they also resonate differently with the memory, associations and feelings of each person who sees or handles them.

Nature Of Things is based on organic, biomorphic, almost aquatic forms, and comes out of Inuzuka's recent experience of returning to the West Coast to live and work. The simultaneous contradictions in *Nature Of Things* - between mass and detail, the imposing and the intimate - are as much about the experience of walking down a New York street as they are about standing beside the ocean. ~



Greenwich House Pottery, New York City

COMPUTERS

By Jill Dacey, With Christopher Leitch

Computers are not necessarily new tools. The prototype for todays sophisticated PCs and mainframes is the now-axotic 19th century "analytical engine" designed by Charles Babbage and refined with him by Ada Byron, Lady Lovelace. The Countess Lovelace, an accomplished mathematician, was informed in her work by observing and analyzing jacquard looms with their many punched wooden and paper cards and direct on-off operational logic, from which she devised the basic principles of contemporary computer programming. The jacquard, as all good textile artists know, uses millennia-old technology perfected by draw looms and tablet-weaving.

Computers are becoming useful to textile artists and designers. Most printed-textile manufacturers are using computers, sometimes for original designs, and for conversion of designs to exact repeats and print-ready manufacturing specifications. Some companies are using colour print-outs, on paper or fabric, as headings for direct orders, thus eliminating the necessity of set up before orders are received.

New Tools Of The Trade

Software specific to the textile print design industry is expensive, complicated and often requires large, sophisticated operating systems. However, personal computers are changing and evolving to be more useful to designers and individual artists. Inexpensive off-the-shelf programs can be adapted to surface design, including Adobe Photoshop™, Pixelpaint Pro™, Painter™, and Freehand™. These programs can be used to generate repeat designs, colourways, and colour separations for making screens, and for manipulating scanned images. Computer hardware is becoming less expensive and more powerful, including flat-bed scanners, data storage devices, and printers. Output devices are more readily available, including large format colour

printers. An individual artist need not own all the requisite equipment - service bureaus are available with scanners for input and sophisticated printers for colour output and transparencies.

Frank Cronk and Jill Dacey, at the University of Idaho, use computers frequently in the surface design studio and classroom. They find principles of colour interaction and positive and negative space are easy to convey to students in print design with quick changes via a computer and Adobe Photoshop software. They scan in students' croquis to manipulate colour, placement, and size to see numerous combinations without hours of painting and repainting.

Students also use the computer to do original designs and colourways. These are printed on a colour laser printer, stored on disk, or made into slides. Students can produce laser print separations on transparencies for making screens. Cronk and Dacey also use a version of AVL WeavePlanner in weaving classes to illustrate concepts in pattern drafting, and treading and threading effects. The students also use this program for designing weaves and projects.

On-Line Textiles

Cronk and Dacey are in the process of developing interactive tutorial software for textile design that addresses traditional approaches to styles, motifs, and repeat concepts. They have also developed visuals to display the concept of quartering and its use in putting a pattern into repeat, as well as the special characteristics of triangle, diamond, scale, and ogee repeats. When completed, the program will be able to put any motif into all the various forms of repeat, allowing a student or artist to quickly assess the best repeat layout for a particular motif.

Many associations and groups are addressing the needs for education in this area. Textile Arts Forum: for a free ten hour trial, dial 1-800-695-4002; at User-name, enter JOINDELPHI and at password, enter CUSTOM 135. The Computer Integrated Textile Design Association, is committed to the management, and development of computer integrated design and manufacturing systems within the textile industry. Contact CITDA at PO Drawer 40399, Raleigh, NC 27629-0399. ☞

DICTIONARY

CROQUIS from the French croquer, to crunch; a sketch or study; especially a preparatory drawing or design for a proposed work of art.

HARDWARE the basic computer, including microchips, wiring, and other internal elements; monitor or display; keyboard; mouse

SOFTWARE the electronically encoded and recorded instructions that allow the machine to help generate graphic images of work

OPERATING SYSTEM software which is used to open and utilize proprietary, or brand name software applications. Macintosh, OS2, DOS, and UNIX, are operating systems.

CROSS-PLATFORM refers to software which has versions that can be run on different operating systems. All operating systems will not run all software

INPUT DEVICES hardware that translate images and text into the form of electronic data to be manipulated by specific software, including scanners, video cameras, digitizing cameras

OUTPUT DEVICES hardware that produce images from a computer on paper, transparencies, or slides

house pro-
vides an outlet for
the display and sale of
fine traditional, contemporary,
and leading edge crafts; and provides
information and education to the CABC
membership, general public, professionals
in the visual arts community, and
craftspeople. Crafthouse aims to be self-
supporting in its promotion of craft.

Mementos, Talismans And Other Travel Sketches

Dominique Bréchnaut – October 5 – 31 In The Alcove Gallery

Reception: October 5 – 6 pm To 8 pm

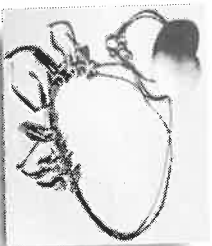

"Autumn," by Dominique Bréchnaut

The show comprises over 20 pieces of jewellery and related objects produced in the last year and a half. Silver and gold, these pieces also incorporate non-metallic materials, such as wood and bone or found objects.

She uses a number of processes, some fairly unusual, like Keum-Boo, an old Korean technique for applying gold to silver. In her piece "Dance Lessons,"

she challenges the traditional definition of jewellery, as the piece is designed to function with or without the wearer.

Travels and journeys are the inspiration for her show as "they provide a vast supply of images – text which I later incorporate in my jewellery.

...gathering the information, recording and mapping is a significant part of the creative process involved in the making of each piece. It constitutes yet another journey." Several pieces possess strong narrative elements; some are mementos, others talismans. Through personal images and metaphors, Bréchnaut's

work expresses a wide range of strong emotions. These intriguing images are Bréchnaut's own icons. Because of the emotions and honesty they convey, it is easy for us to relate and be drawn to them. 

SHOP TALK

Volunteers are an integral part of our job of promoting and selling the work of Crafthouse artists. Granville Island is a vibrant community and Crafthouse is an exciting place to work. If you are interested in volunteering in a shop surrounded by beautiful craft please contact Jo at 687-7270. Many thanks go to our current volunteers: Martha Casey-Knight, Charlotte Lightburn, Elizabeth Owre, Kandice Kwok, and Masumi Wada. Crafthouse says goodbye to Rosanna Tsao, Denise Lai and Ingrid Su who return to school and paid employment.

Crafthouse will be closed Nov. 13-14 while the shop is dressed for the Holiday Season. On Nov. 14, 6-9 pm the doors will open to CABC members and Crafthouse customers for the first opportunity to view the new holiday work. Remember your new holiday work. Remember your 10% discount. Nov. 15-19, we will open at 8 am, following last year's tradition of early holiday shopping. Coffee will be served and parking couldn't be easier!

Crafthouse extends its sincere thanks to Peggy McLernon, and Mr. D. McLernon of Multi-Pak for their generous donation of 5,000 shopping bags.

Branching Out: New Furniture

Matt Vander Werff – November 2 To December 5 At The Alcove Gallery

Reception: November 2 – 6 pm To 8 pm

Matt Vander Werff is known primarily for his birchhouses. He incorporates readily available, recyclable materials in his work as design elements, including sheet copper, glass, and galvanized aluminium.

Vander Werff states his first criteria is functionality, with decoration and embellishment serving as important components of a piece. Vander Werff has also been

pulled by rural architecture and looks for elements to reflect these influences.

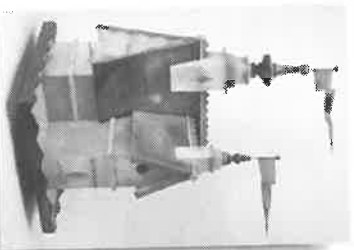

Untitled, by Matt Vander Werff

Though his work can be seen as whimsical, it is eclectic enough to work in different environments – from the traditional home to a stark, modern office.

While he has been in group shows in both Vancouver and Toronto, most of his work in Vancouver has been on commission. His first show at Crafthouse will offer us a look at wall clocks, mantle clocks, functional wall cupboards, tables and lamps.

Using simplicity and new interpretations of common materials, Vander Werff's work reminds us of a time when craftsmanship was important. He believes that a resurgence of the artisan movement is underway as people increasingly seek handcrafted elements in their lives. 

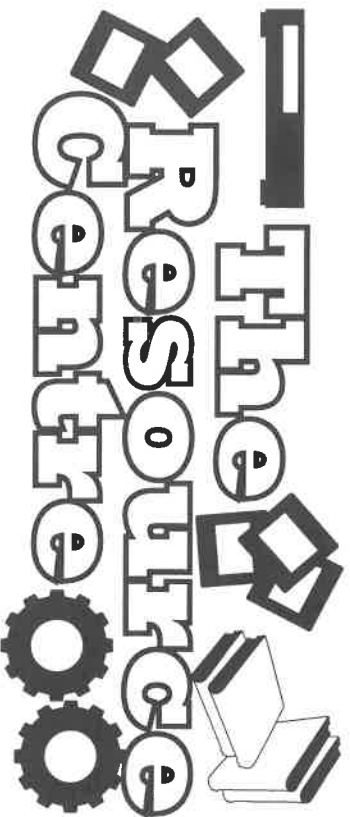

The Resource Centre

The CABC Resource Centre provides a wealth of information for craftspeople and the general public. Located in the CABC offices, the Resource Centre includes the Video Lending Library, the Portfolio Registry, and the Resource Library. We encourage all of our members to make use of these resources. For more information or to make an appointment, contact Fiona Macleod at 687-6511.

Video Lending Library

A resource of 48 titles available for loan to artists/craftspeople, educators, curators, architects/designers, collectors, and others interested in crafts. Videos feature profiles of artists and their work in clay, fibre, glass, metal, and mixed media. For a complete list or to borrow any of these videos, contact the CABC office at 604-687-6511, or fax 604-687-6711.

The Portfolio Registry

The Registry contains portfolios of CABC members displayed in a format that provides easy access to other professionals. To join the Registry, send us:

- ★ 6-8, 35 mm slides of your work.
- ★ A typed resume or CV.
- ★ Published material about you or your crafts.

The Registry is updated periodically and submissions may be made at any time. If you already belong to the Registry, you should update your portfolio periodically to make sure your submission contains current material and is in the appropriate format.

The Resource Library

Here are our latest additions available for use within our offices, Tuesday to Friday:

Publications

- ★ *Start And Run A Profitable Gift Basket Business*. Self Counsel Press, 1995.
- ★ *Crafts In Ontario: Shop And Galleries*. Ontario Crafts Council, 1994.
- ★ *Suppliers Of Craft Materials In Ontario*. Ontario Crafts Council, 1994.
- ★ *Photographing Your Craftwork*. Steve Melzer, 1986.
- ★ *Annual Craft Shows In Ontario*. Ontario Crafts Council, 1995.

Periodicals/Newsletters

- ★ *Canadian Workshop - The Do-It-Yourself Magazine*.
- ★ *Needle Yarns*. Newsletter from the North Shore Needle Arts Chapter.

Bulletin Boards

Located at the back of Crafthouse, just before you go up the stairs to the Resource Centre, you'll find bulletin boards. They hold lots of information about current exhibitions, seminars, studio space, calls for entry, and job opportunities that are available in the arts.

NEW ACQUISITIONS

Here are the latest additions to our Resource Library which are available for use within our offices, Tuesday - Friday. Please call to make an appointment, 687-6511.

Publications:

- ★ *SOFA catalogue, 1994* - Sculptural Objects Functional Art exhibition in Chicago
- ★ *The Guild, Contemporary Crafts, 1995* - sourcebook of North American craft artists
- ★ *The Guild, Buyer's Guide, 1995* - a companion volume for the trade
- ★ *Rural Craft Development Project, 1995* - an excellent report defining and developing the craft industry in Alberta produced by the Alberta Crafts Council
- ★ *Collectible Beads* by Robert Liu, 1995 - from the publishers of Ornament, a beautiful book

Business Information

From Industry Canada

- ★ A Guide to Industrial Designs
- ★ A Guide to Patents
- ★ A Guide to Copyrights
- ★ A Guide to Trade-Marks

So, You Want to Export. Dept. of Foreign Affairs and International Trade, 1995.

Trade-Mark Fee Structure

THE NEWS

ON THE ROAD AGAIN

The Canadian Conference Of The Arts will once again be travelling across the country to hear the views of artists and cultural workers on a variety of issues. Join them in developing a plan to ensure that all parts of the cultural sector remain vital and strong. Meeting in Vancouver on Oct 23, 2-4 pm at the Vancouver Cultural Alliance, 938 Howe Street. For more information contact Susan Annis 613-238-3561.

ECLAD OPEN HOUSE

70th Anniversary Celebrations will commence Oct. 21-22 with the Emily Carr Institute Of Art And Design open house. The public is welcome to attend the open house, which promises to be informative, educational and entertaining. For further information, contact Sylvia Iredale 844-3871.

VOLUNTEER

The Vancouver Volunteer Centre operates a publications service featuring a number of resources of interest to community arts organizations. Publications range in price for \$6 to \$37. For an order form and list of titles, contact the Centre's Publications Division, 301-3102 Main St., Vancouver, BC 604-875-9144.

CERAMICS REGULATIONS

The Federal Government is revising their glazed ceramics regulations. Changes which may affect artists apply to all products made wholly or partially of ceramic or glass that are:

◆ for food use or that may be used in storing, preparing or serving food as defined in the Food And Drugs Act; and

◆ covered completely or partially with a coating, glaze, or decoration that contains lead or cadmium.

For a copy of the proposals, or to find out more about how the proposed changes may affect you contact: Health Canada Product Safety, 17th Floor, Zone 6, Place du Portage, Phase 1, 50 Victoria Street, Hull, PQ K1A 0G9.

NEW HEAD

The Canada Council has appointed Margaret Dryden as Head of the Visual Arts Section.

ANOTHER ONE GONE

The Northwest Fiber Network of Eugene, Oregon has had to cease operation as of August 7. They cite a lack of time and money as the reasons for their demise.

WORKING WOMEN

According to BC Stats, women in BC are more likely to work part-time than women living in the rest of the country. In 1994, 29% of employed women in the province worked part-time, compared to the Canadian average of 26%. In Canada, 69% of all part-time jobs were held by women, a figure that has changed little over the past two decades.

Over half of all women in BC are employed in the labour force. In 1994, 54% of women in BC aged 15 and over had jobs, compared to 52% nationally. By contrast, 67% of men in BC had jobs.

The female unemployment rate in BC was the lowest in the country in 1994, at 8.5%, compared to a Canadian average of 9.9%. The rate for men in BC was much higher, at 10.2%

SASQUATCHESS?

The Harrison Hot Springs Chamber of Commerce is launching its first Oktoberfest, with a Thanksgiving and Harvest Time theme, Oct. 12-15.

The mascot for the Oktoberfest is "Suds the Sasquatch" with "Suddy the Sasquatchess" as his partner.

VISUAL ARTISTS

The Cultural Services Branch of the Ministry Of Small Business, Tourism And Culture offers a program of assistance for individual artists to assist with specific creative projects. One juried competition is held annually. Under normal circumstances, applicants must

- ✓ be professional visual artists with a min. of 5 years experience
 - ✓ have had a min. of 2 professionally curated exhibitions
 - ✓ have been residents of BC for at least 12 months prior to making application and must be Canadian citizens or landed immigrants.
- Phone 356-1728 or Fax 387-4099 for more information.

THE CRAFTSPERSON'S RESOURCE GUIDE TO BRITISH COLUMBIA 1994/95

- Yes, I am a CABC Member! Send me one Resource Guide for \$8.56 (plus \$2.00 p&h).
- No, I am not a CABC Member yet. Send me one Resource Guide for \$9.63 (plus \$2.00 p&h).
- Payment Enclosed
- Visa/Mastercard

NAME _____

STREET _____

CITY _____ PROV. _____ CODE _____

PHONE _____ FAX _____

VISA/MASTERCARD NUMBER _____ EXPIRY DATE _____

SIGNATURE _____

Includes:

- Retail Outlets
- Galleries
- Craft Fairs
- Suppliers
- Education
- Craft Guilds
- Organizations

Return to:

Crafts Association of B.C.
1386 Cartwright St., Granville Is.
Vancouver, British Columbia
V6H 3R6

Candlesticks

October 1 To December 8, 1995
 Art At Terminal 3 – Toronto, ON

Sponsored by Terminal Three Limited
 Partnership, The Claridge Collection,
 And Canadian Airlines

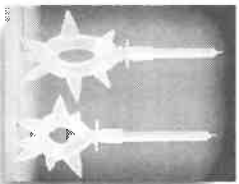

"Spiky Candle," by
 Jeff Burnette & Lisa
 Samphire

Participating BC Artists

- ✦ Nina Di Giovanni
- & Marcus Sabathill
- ✦ James Koester
- ✦ Brooke Hannah
- ✦ Eva Mansson
- ✦ David Milligan
- ✦ Jeff Burnette & Lisa Samphire
- ✦ Chuck St. John
- ✦ Nancy Walker
- ✦ Marc Was

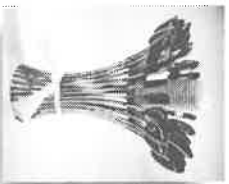

"Harvest," by Brooke
 Hannah

The Crafts Association Of British Columbia along with Franklin Silverstone, Curator; Terminal 3, Toronto; Prime Gallery, Toronto; Provance, Calgary; Elena Lee Gallery, Montreal; and the New Brunswick Craft Council, Fredericton will participate in Art at Terminal 3's Seventh Show – Candlesticks.

We gratefully acknowledge the financial support of the Government Of British Columbia through the Ministry Of Small Business, Tourism and Culture.

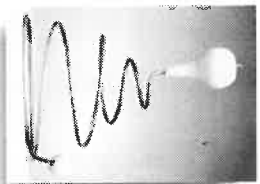

"Bulb Candle Holder,"
 by Eva Mansson

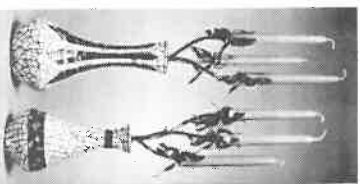

"La Noche Catalana,"
 by Nina Di Giovanni
 & Marcus Sabathill

NEW CO-CHAIR FOR GOV. GEN.'S AWARDS

Quebec actress Monique Mercure has been named as Co-Chair of the Board Of Directors for the Governor General's Performing Arts Awards.

Three well-known representatives of Canada's artistic community, Toronto composer Alexandra Louie, Montreal dancer and choreographer Paul-André Fortier and Vancouver radio and television broadcaster Vicki Gabereau, have

joined the Foundation Board this year.

Each year the Governor General's Performing Arts Awards honour six performing artists for their lifetime achievement and contribution to the

cultural enrichment of Canada. The Awards are administered by The Governor General's Performing Arts Awards Foundation, a non-governmental, not-for-profit, charitable organization.

MasterCard Discount A Terrific Deal!

1.85% The CAB C is pleased that a new benefit is

now available to all our members. The Bank of Montreal MasterCard merchant financial institutions in BC (i.e., Richmond Savings Credit Union, Bank of BC/ Hong Kong Bank of Canada, Interior Savings Credit Union, and Pacific Coast Savings Credit Union) are now offering a preferred merchant discount rate of 1.85%. This is a great opportunity for members who are already MasterCard merchants, and is an opportunity for those who are not, to possibly enhance sales and customer service through offering MasterCard. If you are a CAB C member who currently accepts MasterCard through one of the above institutions and wish to take advantage of the 1.85% discount rate, complete the form and forward it to the CAB C. For more information contact Lisa Chapman at the Bank of Montreal at 665-7465.

MasterCard Discount A Terrific Deal!

BANK OF MONTREAL OR AFFILIATE BANK MERCHANT NUMBER

TRADE NAME

ADDRESS

CONTACT NAME

DEPOSIT/FINANCIAL INSTITUTION

ACCOUNT NUMBER

TELEPHONE

Return To:

Crafts Association of British Columbia
 1386 Carthwright Street, Granville Island
 Vancouver, British Columbia V6H 3R8

CRAFT CALVADA

GALLERIES/MUSEUMS

CANADIAN CRAFT MUSEUM

Hands On Wood - Aug. 30 To Nov. 18. Showcasing 27 BC artists who work with wood or incorporate it in their craft, bringing together various items from furniture to musical instruments. Contact Giovanni Festa 687-8266.

VANCOUVER ART GALLERY

Space, Time, And Memory: Photography And Beyond In Japan - Oct. 18 To Dec. 10. Contact 682-4668

ART GALLERY OF GREATER VICTORIA

Ceramics by Peter Flanagan and handpainted and printed textiles by Mignon Smitenk - Oct. 5-30. Contact 384-4101.

HARBOURFRONT CENTRE (TORONTO)

The Age Of Anxiety - Sept. 22 To Nov. 26. Nine contemporary artists address vital questions of national, cultural, and personal identity at a watershed moment in Japan's history. Contact 416-973-4518.

UNITARIAN CHURCH OF VANCOUVER

Human Persons - Human Absence - Oct. 8 To Nov. 5. An exhibition of tapes-tries by Jane Bartlett, Barbara Heller, Alison Keenen, Margaret Kajner, Antheo Mallinson, and Kaija Rautiainen. 949 West 49th Ave, Vancouver.

CRAFT CALVADA

Contact Fiona MacLeod

TEL: 687-6511 FAX: 687-6711

Next Deadline: November 7

Display Ad Rates:

1/4 page-\$35 1/2 page-\$90

1/4 page-\$45 Full page-\$175

Display ads must be provided camera-ready. Call for details.

CIRCLE CRAFT GALLERY

Yvonne Wakabayashi and two jewellers will have work on display for the month of Oct. 6 to 8 pm. Circle Craft Gallery, Net Loft, Granville Is., Vancouver.

OPPORTUNITIES

The Cafe International-Located in the Emerson Cultural Centre, The Cafe has a display area for Canadian artists. Display is free with certain restrictions. Contact Andy Hassanali, 808 1/2 N. Block, Bozeman Mt 59715, 406-586-6716.

Auction For The Arts-A silent and verbal auction featuring fine art, and collectibles. Oct. 28, 5:30 pm, 15 NW Birch, Coupeville, WA. Contact the Coupeville Arts Center 360-678-3396.

For Sale-Leclerc Colonial 45" Loom. This loom can be a 4 harness counter-balanced loom with adjustable harness heights. \$1,350. O.B.O. 604-946-5339.

For Sale-Bookbinding equipment, materials, and high quality leather suitable for a variety of craft work. Enquiries evenings 926-2706.

For Sale-AVL Loom, 48", 4 Harness Dobby Convertible Loom with automatic cloth storage system, fly shuttle, and auto advance. Includes delivery and set-up in Lower Mainland area. \$5,000. 872-4965.

No room to pursue floral arrangements hobby. Loose silk and dried flowers, containers and arrangements available at reasonable prices. Phone 604-433-4331 (days only).

The Bronze Gallery-Seeks wall hangings to complement sculpture shows. Send slides to Sutomi. The Bronze Gallery, 227 Granville St., Vancouver, BC 604-737-8867.

Canadian Craft Museum Shop-We invite jewellers from across Canada to submit slides or 2-3 samples of your work for consideration by the selection group. Please send to the attention of the Canadian Craft Museum Shop, Cathedral Place Courtyard, 639 Hornby St., Vancouver, BC V6C 2G3.

Van Dopp & Associates-seeks Canadian craft for 3 galleries. Interested in all mediums: clay, ceramic, glass, fibre, metal, and mixed media. One of a kind and production work. Now accepting applications for our upcoming Christmas Show "Spirit Of The Season." Forward slides/photos, artist's statement, and updated CV to Trudy Van Dopp, 421 Richmond St., New Westminster, BC V3L 4C4.

Art Gallery Of Greater Victoria-Art Rental and Sales is exhibiting ceramics by Gary Merkel (Gemini Series) Sept. 14 to Oct 2. Artist's reception Sept. 14, 7-9 pm.

Candle Business For Sale-9 years in business. All equipment, extensive client list, and training included. Contact Chris at 732-3167.

Banff Visual Arts-Time and space for visual artists. Summer, winter, and fall terms. Financial aid available. Contact The Banff Centre, PO Box 1020, Banff, AB T0L 0C0 403-762-6180

For Sale-23 lbs shorn llama fiber, uncarded. Colours: off-white, light grey, red-brown, black. Lot price: \$300. Phone 467-8555.

Canadian Craft Museum Resource Library-Houses info about artists which is available to architects, designers, and museum members who wish to include art in homes and work places. Gillian Schick. Communications Director, Canadian Craft Museum, 639 Hornby St., Vancouver, BC.

CRAFT CANADA

The Craft Gallery Of The Ontario Crafts Council—Submit proposals, slides, and resume with SASE to Dale Barrett, Curator, The Craft Gallery, Ontario Crafts Council, Chalmers Building, 35 McCaul St., Toronto, ON M5T 1V7, 416-977-3551.

CONFERENCES

SOFA CHICAGO 1995 NOVEMBER 2-5

The international exhibition of Sculpture, Objects, and Functional Art. Major galleries and dealers from the US, Australia, and Canada will present the best and most innovative in 3 dimensional art. SOFA Chicago 1995 will be held at Navy Pier in Chicago and includes a full schedule of symposia, lectures, and special events. For information, call 312-654-0870.

ANNUAL ARTIST'S RETREAT FEB. 5-10, 1996

Mauna Kea State Park, Island of Hawaii. \$220 per person includes 5 nights lodging and all meals. Focusing on Hawaiian plant fibres and their uses (paper, tapa, and lei making). SASE for more info: Marilyn Wold, PO Box 5202, Aloha, OR 97006, 503-641-2294.

3RD ANNUAL INTERNATIONAL BEAD CONFERENCE NOV. 17-19

Washington, DC. Workshops, exhibits, gatherings, international bead bazaar. P.O. Box 2666-0666, Fairfax, VA 22031, 410-987-1884.

GRANTS & AWARDS

GOEBEL CANADA

Annual international awards for porcelain sculpture totalling \$25,000. Contact Marcel Brandstet, President, Goebel Canada, 1200 Carnforth Road, Toronto, ON M4A 2K7.

INDEPENDENT PROJECTS FELLOWSHIPS

John Simon Guggenheim Memorial Foundation awards one-year fellowships (e.g., US \$26,500) for artists to pursue independent projects. Applicants must be US or Canadian citizens. Contact: The John Simon Guggenheim Memorial Foundation, 90 Park Ave., New York, NY 10016 or call 212-687-4470.

SHEILA HUGH MACKAY FOUNDATION

The Sheila Hugh Mackay Foundation was established to promote public knowledge, participation in and appreciation of Canadian arts and crafts and their importance in the cultural heritage of Canada. Amounts between \$250 and \$500 have recently been awarded to 29 artists and associations across Canada, including *Marlene Weston* and *Vivienne Pearson* from British Columbia. Next deadline is Oct. 31. For info, contact The Sheila Hugh Mackay Foundation, Box 737, Rothesay, NB E2E 5A8 or phone 506-847-5322.

ARTS AWARDS SERVICE

The Canada Council offer 4 types of grants to Canadian artists of all world cultures who are recognized as professionals by their peers and who have a history of public presentation. Deadlines vary according to discipline. For a free brochure contact: Arts Awards Service, The Canada Council, P.O. Box 1047, Ottawa, ON, K1P 5V8, or TEL: 800-263-5588 or FAX: 613-566-4342.

ARTS APPRENTICESHIP

Grants are available up to a maximum amount of \$15,000 for a 10 month training period or \$1,500 per month. For information contact: Program Officer, Arts Apprenticeship Component, Heritage Cultures and Languages Program, Dept. of Canadian Heritage, 365 Laurier Ave. West, Ottawa, ON K1A 0M5, or phone 819-953-9385.

Out of Hand
presents
The 5th Annual
Christmas
Craft Fair
at the
VICTORIA
CONFERENCE
CENTRE
NOV 16-19

FOR INFORMATION CONTACT
Ramona Froehle-Schacht
Box 35028, Victoria, B. C.
V8T 5G2
Phone & Fax 592-4969

ARTS & CRAFT FELLOWSHIPS

For artists and craftspeople under 35 from Commonwealth countries: Up to \$6,000 for younger artists to work with more established artists for up to 9 months. Covers return airfare, accommodation, subsistence, and cost of mounting a show of resulting work. Deadline: Oct. 1. Contact: Commonwealth Foundation Fellowships in Arts and Crafts, Gloria Maddy, Commonwealth Institute, Kensington High St., London, England W86NQ, or call 071-603-4535, ext 300.

CANADA COUNCIL

Ongoing awards to artists through the Jean A. Chalmers Fund for the Crafts: Criticism and Curating, Project and Travel Grants, Visual Art Grants. Contact The Canada Council, P.O. Box 1047, 350 Albert St., Ottawa, ON K1P 5V8 or call 1-800-263-5588.

CRAFT CALYNDAS

MARKETS & FAIRS

Langley Weavers' & Spinners' Artists' Sale—at Fort Langley Community Hall, Glover Road, Fort Langley, BC. Nov. 11-12 from 10 am to 5 pm.

CALL FOR ENTRIES

1996 Filberg Festival—Put your name on eht mailing list for a Jury Application Form by calling Sylvia Allan at 604-334-9242, or Fax 604-334-2899. Deadline is Dec. 1. Leave name, address, phone number, and your craft medium/category. If you want a return call before the package is mailed, please say so in your message.

CALL FOR ENTRIES

National Council On Education For The Ceramic Arts—Canadian visual artists are invited to submit work for a juried exhibition entitled "Canadian Clay Currents," that will travel to NCECA, the annual ceramics conference held this year in Rochester, NY. Works must be made primarily, but not necessarily entirely, of ceramics and incorporate a theme of technology. Deadline Nov. 31. Contact Melody Lindbom 614-263-3579.

CALL FOR ENTRIES

The Ferry Building Gallery—Selected artists' work will be scheduled for an exhibit in the Ferry Building Gallery between Feb. and July, 1996. Must be a past or present resident of the North Shore. Deadline Oct. 15. Contact Ruth Payne 925-7290.

CALL FOR ENTRIES

Vahki Annual—Open to all contemporary American crafts. Deadline: Oct. 10. Galeria Mesa, PO Box 1466, Mesa, AZ 85211-1466, 602-644-2242.



ENTERPRISE HALL
in
PLAZA OF NATIONS
at
760 Pacific Blvd.
NOV. 9-12

FOR INFORMATION CALL
Simone Avram
VANCOUVER CRAFT MARKET
8540 Demorest Drive, Rich.
Tel/Fax: 275-2724

VERONIKA GEVERS RESEARCH FELLOWSHIP IN COSTUME AND TEXTILE HISTORY

Up to \$9,000 to be awarded to a scholar working on any aspect of textile or costume history whose research makes direct use of, or supports any part of the ROM collections that cover a broad range of time and geography. Deadline: Nov. 15. Contact Chair, Veronika Gervers Memorial Fellowship Textile Dept., Royal Ontario Museum, 100 Queen's Park, Toronto, ON M5S 2C6 or phone 416-586-5790.

CRAFT GALLERY

The Ontario Craft Council accepts proposals with slides, resume, and SASE. Contact Dale Barrett, Curator, The Craft Gallery, Ontario Arts Council, Chalmers Bldg., 35 McCaul St., Toronto, ON M5T 1V7, or call 416-977-3551.



The Juniper Berry
POTTERY STUDIO
and
B.C. CRAFTS GALLERY
since 1987
1215 MAIN STREET SMITHERS B.C.

Inviting artists and craftspeople looking for new markets to send work North! We take items on consignment or buy outright on occasion. We are seeking seasonal handmade decorations and gift items for our big Christmas season. Well established. References available

Contact Tenley
847-9871

or write Box 572
SMITHERS B.C. V0J 2N0

CALL FOR ENTRIES

Explorations In Wood '96-A juried exhibition to be held at the Maltwood Art Museum And Gallery, Jan. 28 to Mar. 22, 1996. Contact The Vancouver Island Woodworker's Guild, Victoria, BC, 604-592-4938.

CALL FOR ENTRIES

Pioneer Square Studio/Gallery—Reviewing work of new and emerging visual artists for first Thursday gallery walk exhibit. Deadline: unspecified. SASE for info to: ACE Studios/Exhibit Review, 619 Western Ave., Box #16, Seattle, WA 98104.

CALL FOR ENTRIES

Absolutely Beads 1995—Jewellery and bead art from AB, AK, BC, ID, Mt. OR, Wa. Deadline: Oct. 5. Beads and Beyond, 25-102nd Ave. NE., Bellevue, WA 98004, 206-462-8992.

CRAFT CALAMDA\$

CraftWorld

Fine Arts & Crafts Show

Comes to B.C.

Cloverdale Fairgrounds,

Surrey, B.C.

October 27-29

Fri 1-9; Sat 10-6; Sun 10-5

Cydemar Productions Inc.

519 351-8344 Fax 519 351-8345

CALL FOR ENTRIES

6th Annual Professional Craft Fair

Nov. 2-5, Nanaimo, BC. Professional crafters invited. For info, contact

Deanna at 758-3520, FAX 390-1049 or write 6010 Uplands Drive, Nanaimo, BC V9V 1M1

The Coupeville Arts Center sponsors

workshops in fiber arts. City & Guilds of London Embroidery courses with Gail Harker beginning Sept. and Oct.

Coupeville Arts Center, 15 NW Birch, PO Box 171, Coupeville WA 98239, 360-678-3396.

CALL FOR ENTRIES

VanDusen Craft Markets—Require

garden-themed crafts. Please contact Barb Cook, 261-7660 for further info.

1. October 6, 7, and 8, 1995
2. November 3, 4, and 5, 1995

Guild Of Canadian Weavers offers a

self-guided home-based text program leading to a Masterweaver certificate. 4 bulletins per year, access to a library of textile books and videos, scholarships, travelling exhibits, and more. Contact Rosalie Williams, GOCW, 9102 Cherry Lane, Vernon, BC V1B 1V9.

CALL FOR ENTRIES

The Quilt Project—Women's Art Resource Centre seeks submissions - a

collection of diverse quilts by Canadians to be displayed in a permanent location. Submissions should document the lives, beliefs, and travels of the artists or their families. Contact The Quilt Project, WARC, 309-394 Euclid Ave., Toronto, ON M6G 2S9 416-324-8910.

WORKSHOPS/EDUCATION

Metchoin Int'l School Of Art is offer-

ing a ceramic workshop with Lana Wilson of California, Oct. 21-22. Cost is \$90 (incl. GST and lunch). Contact Meira Mathison, MISSA, RR#1, Pearson College, Victoria, BC V9B 5T7 604-478-5591.

Seattle Arts Commission Request to be

added to mailing list for Seattle Arts Newsletter and ask to receive any current public art prospectus. There is no charge for newsletter. 100-221 First St., Seattle, WA 98119-4223, 206-684-7171.

JURIED SHOWS

Fall, 1995 Oct. 27-29, Mayfield Inn Trade Centre, Edmonton.

Christmas, 1995 Dec. 3-4, St. Albert High School, St. Albert

Spring, 1996 May 6-7, Akinsdale Arena, St. Albert.

Contact Quality Craft Show, 12 Wheatstone Crescent, St. Albert, Alberta T8N 3G5, or phone Wendy 403-459-2521 or Shirley 403-458-7979, or FAX 940-7934.

CALL FOR ENTRIES

Vancouver Craft Market—Now accepting applications for 1995 Original Vancouver Craft Market at Van Dusen Gardens, Dec. 8-10, and the Second Annual Classic Christmas Craft Fair Nov. 9-12 at the Plaza of Nations. To apply contact Simone Avram, VCM Promotions Ltd., 8540 Demarest Dr., Richmond, BC V7A 4M1 or phone/FAX 275-2724.

The Surrey Art Gallery is offering a

series of professional development workshops for artists, including "Grants and Funding," "Creating and Hanging an Exhibition," and "Photo Documentation." For info contact Diane Thorpe at 604-596-7461.

Emily Carr Institute Of Art & Design is

pleased to present "Art, Life, And The Bottom Line: A Cost-Benefit Analysis?" a lecture by Ellen Dissanayake on Oct. 10 at 7:30 pm. Dissanayake, an independent scholar lectures about the arts and their importance in human lives, past and present.

Washon Island Sewing Retreat Classes

in apparel patternmaking, etc. SASE to Lorraine Kimmel, 15630-94th Ave. SW, Washon, WA 98070, 206-567-4022.

Pyramid Bronze Works Ltd.
P.O. Box 1755, Station A
Kelowna, BC V1Y 8M3
(604) 763-8239

- Quality fine art castings in Everdur bronze
- From mold making to patinas
- Lost wax process with ceramic shell
- Quarterly weekend bronze casting workshops
- Custom design consultation
- A foundry run by sculptors for sculptors

**Vandusen's "own"
Craft Market**

Garden-themed Crafts

**Fri Nov 3 to Sun Nov 5
10 a.m. to 5 p.m.**

**Vandusen Gardens
Oak St (at 37th Ave)
257-8666**

**8
Successful Years
of Craft Fairs!**

**Craft Market venues
In Nov. and Dec.:**

- **VAN DUSEN GDNS.**
(Vancouver)
- **GLENEAGLES G.C.**
(Vancouver)
- **OAK BAY BEACH
HOTEL** (Victoria)

**For info call Lyn at
(ph) 739-9002
(fax) 739-9004**

SET UP BUSINESS IN MAYFAIR

**Our Kiosk
Leasing Program
is ideal for
your specialty**

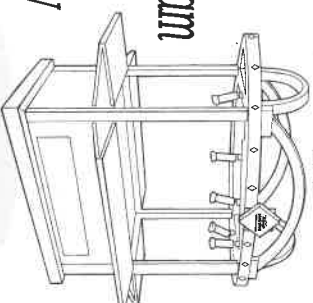

RENT OUR KIOSK FOR YOUR BUSINESS

**Our Kiosk Leasing Program provides endless opportunities
for profit and exposure.**

WE'LL WORK WITH YOU TO BE A SUCCESS

**Our merchandising specialists and temporary tenant literature
will help you achieve maximum results.
Choose Mayfair Shopping Centre
as your new gateway to success in business.**



**SHOPPING CENTRE
Administration Office #221 - 3147 Douglas Street
Victoria, B.C. V8Z 6E3 Phone: (604) 383-0541 Fax: (604) 381-0542**



**XMAS CRAFT
MARKET**

Vancouver Trade and Convention Center

NOVEMBER 22 - 26 1995

**Wednesday, Thursday, Friday:
11 a.m. to 10 p.m.
Saturday, Sunday:
10 a.m. to 6 p.m.**

**Adults \$7.00
Seniors \$4.00
Students \$4.00
Children under 12 free**

THE SHOW WORTH WAITING FOR!

Bring this ad to receive \$1 off adult or showpass admission!

(not to be used in conjunction with any other offer)